

Dell PowerEdge R660

Technical Guide

Notes, cautions, and warnings

 **NOTE:** A NOTE indicates important information that helps you make better use of your product.

 **CAUTION:** A CAUTION indicates either potential damage to hardware or loss of data and tells you how to avoid the problem.

 **WARNING:** A WARNING indicates a potential for property damage, personal injury, or death.

Chapter 1: System overview	5
Key workloads.....	5
New technologies.....	5
Chapter 2: System features and generational comparison	7
Chapter 3: Chassis views and features	10
Chassis views.....	10
Front view of the system.....	10
Rear view of the system.....	10
Inside the system.....	11
Quick Resource Locator.....	12
Chapter 4: Processor	13
Processor features	13
Supported processors.....	13
Chapter 5: Memory subsystem	15
Supported memory.....	15
Chapter 6: Storage	16
Storage controllers.....	16
Supported Drives.....	16
Internal storage configuration.....	17
External Storage.....	17
Chapter 7: Networking	18
Overview.....	18
OCP 3.0 support.....	18
Supported OCP cards.....	18
Chapter 8: PCIe subsystem	20
PCIe risers.....	20
Chapter 9: Power, thermal, and acoustics	27
Power.....	27
Power Supply Units.....	28
Thermal.....	29
Thermal design.....	29
Acoustics.....	30
Acoustical performance.....	30
PowerEdge acoustical specifications.....	31

Chapter 10: Rack, rails, and cable management.....	36
Rails and cable management information.....	36
Chapter 11: Supported Operating Systems.....	46
Chapter 12: Dell OpenManage Systems Management.....	47
Integrated Dell Remote Access Controller (iDRAC).....	47
Systems Management software support matrix.....	48
Chapter 13: Appendix D: Service and support.....	50
Default support levels.....	50
Default deployment levels.....	50
Other services and support information.....	50
Dell deployment services.....	50
Dell custom deployment Services.....	54
Dell Residency Services.....	54
Dell Data Migration Services.....	54
Dell Enterprise Support Services.....	55
Enterprise connectivity.....	57
Dell TechDirect.....	58
Dell Technologies Consulting Services.....	58
Chapter 14: Appendix A: Additional specifications.....	60
Chassis dimension.....	60
Chassis weight.....	61
NIC port specifications.....	61
Video specifications.....	62
USB ports specifications.....	62
PSU rating.....	63
Environmental Specifications.....	63
Thermal air restrictions.....	65
Chapter 15: Appendix B. Standards compliance.....	69
Chapter 16: Appendix C Additional resources.....	70

System overview

The PowerEdge R660 system is a 1U server that supports:

The system features:

- Up to two 4th Generation Intel Xeon Scalable processors with up to 56 cores and optional Intel® QuickAssist Technology
- Up to 32 RDIMMs with up to 8 TB of memory and speed up to 4800 MT/s
- Optional Direct Liquid Cooling
- Two redundant AC or DC power supply units
- Up to 10 x 2.5-inch or 8 x 2.5-inch SATA/SAS/NVMe (HDD/SSD) drives

NOTE: For more information about how to hot swap NVMe PCIe SSD U.2 device, see the *Dell Express Flash NVMe PCIe SSD User's Guide* at <https://www.dell.com/support> > **Browse all Products** > **Data Center Infrastructure** > **Storage Adapters & Controllers** > **Dell PowerEdge Express Flash NVMe PCIe SSD** > **Documentation** > **Manuals and Documents**.

NOTE: All instances of SAS, SATA drives are referred to as drives in this document, unless specified otherwise.

Topics:

- [Key workloads](#)
- [New technologies](#)

Key workloads

The versatile R660 is designed to address data-intensive, diverse workloads including:

- High Density Virtualization
- Dense Database Analytics(VDI)
- Mixed Workload Standardization

New technologies

The table lists the new technologies that are featured on R660.

Table 1. New technologies

Technology	Detailed Description
Intel Sapphire Rapids Processor (Socket E)	Up to 56 core processor
	3 x Intel® Ultra Path Interconnect (UPI) per CPU at 12.8GT/s, 14.4GT/s, 16GGT/s
	80 PCIe Gen4 lanes at 32 GT/s per processor
	Up to 3.6 GHz
	Maximum TDP: 350 W
4800 MT/s DDR5 Memory	Max 16 DIMM per CPU and 32 DIMMs per System.
	Supports DDR5 ECC RDIMM up to 4800 MT/s (1 DPC) / 4400 MT/s (2 DPC)
Flex I/O	LOM board (optional), 2x1Gb with BCM5720 LAN controller

Table 1. New technologies (continued)

Technology	Detailed Description
	Rear I/O with: <ul style="list-style-type: none"> ● 1 x Dedicated iDRAC Ethernet port ● 1 x USB 3.0 ● 1 x USB 2.0 ● 1 x VGA port (optional for liquid cooling configuration) Serial Port Option with STD RIO board OCP Mezz 3.0 (supported by x8 PCIe lanes) Front I/O with: <ul style="list-style-type: none"> ● 1 x Dedicated iDRAC Direct micro-USB ● 1 x USB 2.0 ● 1 x VGA port
CPLD 1-wire	Support payload data of Front PERC, Riser, BP, and Rear I/O to BOSS-N1 and iDRAC.
Dedicated PERC	Front Storage module PERC with Front PERC11 & PERC12
Software RAID	OS RAID/S160
Power Supplies	60 mm dimension is the new PSU form factor with 15G on 16G design. Titanium 700 W AC/HVDC Platinum 800 W AC/HVDC Titanium 1100 W AC/HVDC Platinum 1400 W AC/HVDC 1100 W LVDC -48- -60 VDC Titanium 1800 W AC/HVDC

System features and generational comparison

The following table shows the comparison between the PowerEdge R660 with the PowerEdge R650.

Table 2. Features comparison

Features	PowerEdge R660	PowerEdge R650
Processors	Two 4th Generation Intel® Xeon® (Socket E) processors	Two 3 rd Generation Intel® Xeon® (Socket P14) processors
CPU interconnect	Intel Ultra Path Interconnect (UPI)	Intel Ultra Path Interconnect (UPI)
Memory	<ul style="list-style-type: none"> 32 DDR5 DIMM slots supports RDIMM 8 TB max, speeds up to 4800 MT/s. 	<ul style="list-style-type: none"> 32 DDR4 DIMM slots supports RDIMM 2 TB max or LRDIMM 8 TB max, speeds up to 3200 MT/s. Up to 16 Intel Persistent Memory 200 series (BPS) slots, 12 TB max
Storage Controllers	<ul style="list-style-type: none"> Internal: PERC H965i, PERC H755, PERC H755N, PERC H355, HBA355i External: HBA355e Software RAID: S160 BOSS-N1 	<ul style="list-style-type: none"> Internal: PERC H755, PERC H755N, PERC H745, PERC H355, PERC H345, HBA355i External: PERC H840, HBA355E Software RAID: S150 BOSS-S1 BOSS-S2
Drive Bays	<p>Front bays: Front bays:</p> <ul style="list-style-type: none"> Up to 8 x 2.5-inch NVMe SSD max 122.88 TB Up to 10 x 2.5-inch SAS/SATA/NVMe (HDD/SSD) max 153.6 TB <p>Rear bays:</p> <ul style="list-style-type: none"> Up to 2 x 2.5-inch SAS4/SATA (HDD/SSD) max 30.72 TB 	<p>Front bays: Front bays:</p> <ul style="list-style-type: none"> Up to 4 x 3.5-inch SAS/SATA (HDD/SSD) max 64 TB Up to 8 x 2.5-inch NVMe SSD max 122.88 TB Up to 10 x 2.5-inch SAS/SATA/NVMe (HDD/SSD) max 153.6 TB <p>Rear bays:</p> <ul style="list-style-type: none"> Up to 2 x 2.5-inch SAS4/SATA (HDD/SSD) max 30.72 TB
Power Supplies	<ul style="list-style-type: none"> 1800 W Titanium 200-240 VAC or 240 HVDC 1400 W Platinum 100-240 VAC or 240 HVDC 1100 W Titanium 100-240 VAC or 240 HVDC 1100 W LVDC -48 - -60 VDC 800 W Platinum 100-240 VAC or 240 HVDC 700 W Titanium 200-240 VAC or 240 HVDC <p>Hot swap PSUs with full redundancy.</p>	<ul style="list-style-type: none"> 1400 W Platinum 100-240 VAC or 240 HVDC 1100 W Titanium 100-240 VAC or 240 HVDC 1100 W LVDC -48 - -60 VDC 800 W Platinum 100-240 VAC or 240 HVDC <p>Hot swap PSUs with full redundancy.</p>
Cooling Options	<ul style="list-style-type: none"> Air Cooling Optional Direct Liquid Cooling (DLC) <p>i NOTE: DLC is a rack solution and requires rack manifolds and a cooling distribution unit (CDU) to operate.</p>	<ul style="list-style-type: none"> Air Cooling Optional Direct Liquid Cooling (DLC) <p>i NOTE: DLC is a rack solution and requires rack manifolds and a cooling distribution unit (CDU) to operate.</p>

Table 2. Features comparison (continued)

Features	PowerEdge R660	PowerEdge R650
Fans	Standard (STD) fans /High performance Gold (VHP) fans Up to 4 sets (dual fan module) hot plug fans	Standard (STD) fans /High performance Silver (HPR) fans/ High performance Gold (VHP) fans Up to 4 sets (dual fan module) hot plug fans
Dimension	Height — 42.8 mm (1.68 inches)	Height — 42.8 mm (1.68 inches)
	Width — 482 mm (18.97 inches)	Width — 482 mm (18.97 inches)
	Depth — 822.88 mm (32.39 inches) with bezel	Depth — 772.11 (30.39 inches) with bezel
	Depth — 809.04 mm (31.85 inches) without bezel	Depth — 758.27 mm (29.85 inches) without bezel
Form Factor	1U rack server	1U rack server
Embedded Management	<ul style="list-style-type: none"> • iDRAC9 • iDRAC Direct • iDRAC RESTful with Redfish • iDRAC Service Manual • Quick Sync 2 wireless module 	<ul style="list-style-type: none"> • iDRAC9 • iDRAC Direct • iDRAC Service Module • Quick Sync 2 wireless module
Bezel	Optional LCD bezel or security bezel	Optional LCD bezel or security bezel
OpenManage Software	<ul style="list-style-type: none"> • OpenManage Enterprise • OpenManage Power Manager plug-in • OpenManage SupportAssist plug-in • OpenManage Update Manager plug-in 	<ul style="list-style-type: none"> • OpenManage Enterprise • OpenManage Power Manager plug-in • OpenManage SupportAssist plug-in • OpenManage Update Manager plug-in
Mobility	OpenManage Mobile	OpenManage Mobile
Integrations and Connections	OpenManage Integrations <ul style="list-style-type: none"> • BMC TrueSight • Microsoft System Center • Red Hat Ansible Modules • VMware vCenter and vRealize Operations Manager 	OpenManage Integrations <ul style="list-style-type: none"> • BMC TrueSight • Microsoft System Center • Red Hat Ansible Modules • VMware vCenter • IBM Tivoli Netcool/OMNibus • IBM Tivoli Network Manager IP Edition • Micro Focus Operations Manager • Nagios Core • Nagios XI
Security	<ul style="list-style-type: none"> • Cryptographically signed firmware • Data at Rest Encryption (SEDs with local or external key mgmt) • Secure Boot • Secure Erase • Secured Component Verification (Hardware integrity check) • Silicon Root of Trust • System Lockdown (requires iDRAC9 Enterprise or Datacenter) • TPM 2.0 FIPS, CC-TCG certified, TPM 2.0 China NationZ 	<ul style="list-style-type: none"> • Cryptographically signed firmware • Secure Boot • Secure Erase • Silicon Root of Trust • System Lockdown (requires iDRAC9 Enterprise or Datacenter) • TPM 1.2/2.0 FIPS, CC-TCG certified, TPM 2.0 China NationZ
Embedded NIC	2 x 1GbE LOM card (optional)	2 x 1GbE LOM card (optional)
Networking Options	1 x OCP card 3.0 (optional)  NOTE: The system allows either LOM card or OCP card or both to be installed in the system.	1 x OCP card 3.0 (optional)
GPU Options	Up to 3 x 75 W SW	Up to 3 x 75 W SW

Table 2. Features comparison (continued)

Features	PowerEdge R660		PowerEdge R650	
Ports	Front Ports <ul style="list-style-type: none"> 1 x Dedicated iDRAC Direct micro-USB 1 x USB 2.0 1 x VGA 	Rear Ports <ul style="list-style-type: none"> 1 x USB 2.0 1 x Serial port (optional) 1 x USB 3.0 1 x Dedicated iDRAC Ethernet port 1 x VGA (optional for liquid cooling configuration) 	Front Ports <ul style="list-style-type: none"> 1 x Dedicated iDRAC Direct micro-USB 1 x USB 2.0 1 x VGA 	Rear Ports <ul style="list-style-type: none"> 1 x USB 2.0 1 x Serial port (optional) 1 x USB 3.0 2 x RJ45 1 x VGA (optional for liquid cooling configuration)
	Internal Port: 1 x USB 3.0 (optional)		Internal Port: 1 x USB 3.0 (optional)	
PCIe	Up to three PCIe slots <ul style="list-style-type: none"> 2 x PCIe Gen5 slots 3 x PCIe Gen4 slots 		Up to three PCIe slots <ul style="list-style-type: none"> 3 x PCIe Gen4 slots 	
Operating System and Hypervisors	<ul style="list-style-type: none"> Canonical Ubuntu Server LTS Windows Server with Hyper-V Red Hat Enterprise Linux SUSE Linux Enterprise Server VMware ESXi For specifications and interoperability details, see Dell Enterprise Operating Systems on Servers, Storage, and Networking page at Dell.com/OSsupport .		<ul style="list-style-type: none"> Canonical Ubuntu Server LTS Citrix Hypervisor Windows Server LTSC with Hyper-V Red Hat Enterprise Linux SUSE Linux Enterprise Server VMware ESXi For specifications and interoperability details, see Dell Enterprise Operating Systems on Servers, Storage, and Networking page at Dell.com/OSsupport .	

Chassis views and features

Topics:

- Chassis views

Chassis views

Front view of the system



Figure 1. Front view of 8 x 2.5-inch drive system



Figure 2. Front view of 10 x 2.5-inch drive system

Rear view of the system

Rear view of the system



Figure 3. Rear view of the R660 with 3x LP



Figure 4. Rear view of the R660 with 2x 2.5 inches Storage drives, 1x LP

Inside the system



Figure 5. Inside view of the chassis without risers

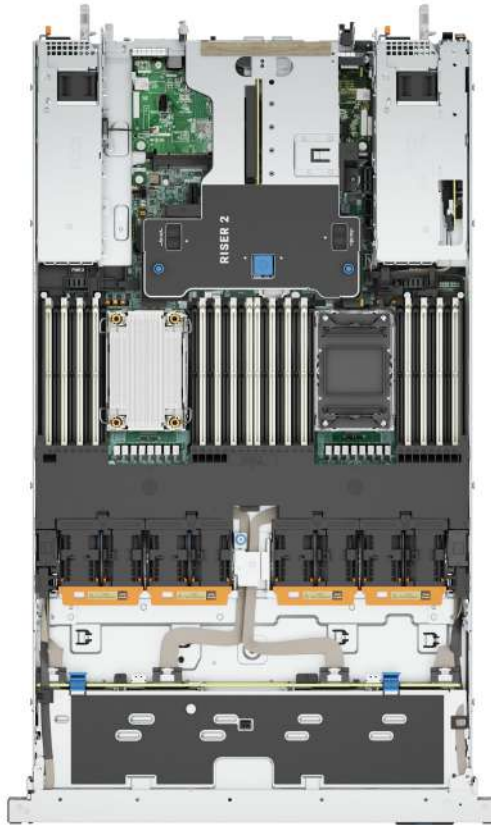

Figure 6. Inside view of the chassis with riser 2

Quick Resource Locator

The QRL on everything (SILs, GSG, Installation and Service Manual except on the EST) is a generic QRL for R660 that leads to a webpage for that product. That webpage has links for things like setup and service videos, iDRAC manual, and other things that apply to the platform. The QRL on the EST is unique and specific to that service tag and will contain the Service Tag number and the iDRAC password. The label and the QRL code within it are printed on demand at the L10 factories. This QRL links to a webpage that shows the exact configuration as built for that customer, and the specific warranty purchased. It is one click away from the same content of generic information that applies to R660 that is available in the other QRLs.



Figure 7. R660 Quick Resource Locator

Processor



Topics:

- [Processor features](#)

Processor features

The Intel 4th Generation Xeon® Scalable Processors stack is the next generation data center processor offering with significant performance increases, integrated acceleration, and next generation memory and I/O. Sapphire Rapids accelerate customer usages with unique workload optimizations.

The following lists the features and functions that are in the upcoming 4th Generation Intel® Xeon Scalable Processor offering:

- Faster UPI with up to four Intel Ultra Path Interconnect (Intel UPI) at up to 16 GT/s, increasing multisocket bandwidth
- More, faster I/O with PCI Express 5 and up to 80 lanes (per socket)
- Enhanced Memory Performance with DDR5 support and memory speed up to 4800 MT/s in one DIMM per channel (1DPC) and 4400 MT/s in two DIMM per channel (2DPC)
- New built-in accelerators for data analytics, networking, storage, crypto, and data compression

Supported processors

The following table shows the Intel Sapphire Rapids SKUs that are supported on the R660.

Table 3. Supported Processors for R660

Processor	Clock Speed (GHz)	Cache (M)	UPI (GT/s)	Cores	Threads	Turbo	Memory Speed (MT/s)	Memory Capacity	TDP
8480+	2	105	16	56	112	Turbo	4800	6 TB	350 W
8471N	1.8	98	16	52	104	Turbo	4800	6 TB	300 W
8470Q *	2.1	98	16	52	104	Turbo	4800	6 TB	350 W
8470N	1.7	98	16	52	104	Turbo	4800	6 TB	300 W
8470	2	98	16	52	104	Turbo	4800	6 TB	350 W
8468	2.1	90	16	48	96	Turbo	4800	6 TB	350 W
8460Y+	2	75	16	40	80	Turbo	4800	6 TB	300 W
8452Y	2	68	16	36	72	Turbo	4800	6 TB	300 W
6454S	2.2	60	16	32	64	Turbo	4800	6 TB	270 W
6430	2.1	60	16	32	64	Turbo	4800	6 TB	270 W
6414U	2	60	16	32	64	Turbo	4800	6 TB	250 W

 **NOTE:** *8470Q and 6458Q are supported only in liquid cooling configuration.

 **NOTE:** Mixing of the processors are not recommended. If a liquid cooled processor is installed in one socket, then the second processor used must be of the same type.

Memory subsystem

Topics:

- [Supported memory](#)

Supported memory

Table 4. Memory technology comparison

Feature	PowerEdge R660 (DDR5)
DIMM type	RDIMM
Transfer speed	4800 MT/s for 1 DIMM per channel, 4400 MT/s for 2 DIMMs per channel
Voltage	1.1 V

The following table lists the supported DIMMs for the R660. For the latest information about supported memory and memory configurations, reference the latest SDL.

Table 5. Supported DIMMs

DIMM Type	Max DIMM Speed (MT/s)	DIMM Capacity (GB)	Ranks per DIMM	Data Width	DIMM Volts (V)
RDIMM	4800	16	1	x8	1.1
RDIMM	4800	32	2	x8	1.1
RDIMM	4800	64	2	x4	1.1
RDIMM	4800	128	4	x4	1.1
RDIMM	4800	256	8	x4	1.1

Storage

Topics:

- Storage controllers
- Supported Drives
- Internal storage configuration
- External Storage

Storage controllers

Dell RAID controller options offer performance improvements, including the fPERC solution. fPERC provides a base RAID HW controller without consuming a PCIe slot by using a small form factor and high-density connector to the base planar.

16G PERC Controller offerings are a heavy leverage of 15G PERC family. The Value and Value Performance levels carry over to 16G from 15G. New to 16G is the Avenger-based Premium Performance tier offering. This high-end offering drives IOPs performance and enhanced SSD performance.

Table 6. PERC Series controller offerings

Performance Level	Controller and Description
Entry	S160
Value	H355, HBA355 (internal/external)
Value Performance	H755, H755N
Premium Performance	H965i, Avenger 1 Memory: 8GB DDR4 NV cache 72-bit memory 2133 MHz Low profile form factors Dual A15 1.2 GHz CPU X8PCIe 3.0, x8 12Gb SAS

NOTE: For more information about the features of the Dell PowerEdge RAID controllers (PERC), Software RAID controllers, or BOSS card, and on deploying the cards, see the storage controller documentation at www.dell.com/storagecontrollermanuals.

NOTE: From December 2021, H355 replaces H345 as the entry raid controller. H345 is deprecated in January 2022.

Supported Drives

The table shown below lists the internal drives supported by the R660.

Table 7. Supported Drives

Form Factor	Type	Speed	Rotational Speed	Capacities
2.5 inches	vSAS	12 Gb	SSD	1.92 TB, 3.84 TB, 960 GB, 7.62 TB
2.5 inches	SAS	24 Gb	SSD	1.92 TB, 1.6 TB, 800 GB, 3.84 TB, 960 GB, 7.68 TB
2.5 inches	SATA	6 Gb	SSD	1.92 TB, 480 GB, 960 GB, 3.84 TB,
2.5 inches	NVMe	Gen4	SSD	1.6 TB, 3.2 TB, 6.4 TB, 1.92 TB, 3.84 TB, 15.63 TB, 7.68 TB, 800 GB, 400 GB
2.5 inches	DC NVMe	Gen4	SSD	3.84 TB, 960 GB
2.5 inches	SAS	12 Gb	10 K	600 GB, 1.2 TB, 2.4 TB

Internal storage configuration

R660 available internal storage configurations:

- Zero drives (no backplane)
- 8x2.5" (NVMe)
- 8x2.5" (NVMe RAID)
- 8x2.5" (SAS4/SATA)
- 8x2.5" Universal
- 10x2.5" (SAS4/SATA)
- 10x2.5" (SAS4/SATA) + 2x2.5" (SAS4/SATA)
- 10x2.5" (SAS4/SATA w/ 4 Universal)
- 10x2.5" (NVMe)
- 10x2.5" (NVMe) + 2x2.5" (NVMe)
- 10x2.5" (SAS4/SATA w/ 2 Universal)

External Storage

The R660 support the external storage device types listed in the table below.

Table 8. Support External Storage Devices

Device Type	Description
External Tape	Supports connection to external USB tape products
NAS/IDM appliance software	Supports NAS software stack
JBOD	Supports connection to 12Gb MD-series JBODs

Networking

Topics:

- [Overview](#)
- [OCP 3.0 support](#)

Overview

PowerEdge offers a wide variety of options to get information moving to and from our servers. Industry best technologies are chosen, and systems management features are added by our partners to firmware to tie in with iDRAC. These adapters are rigorously validated for worry-free, fully supported use in Dell servers.

OCP 3.0 support

Table 9. OCP 3.0 feature list

Feature	OCP 3.0
Form factor	SFF
PCIe Gen	Gen4
Max PCIe width	x16
Max no.of ports	4
Port type	BT/SFP56
Max port speed	100 GbE
NC-SI	Yes
SNAPI	Yes
WoL	Yes
Power consumption	15 W - 75W

Supported OCP cards

Table 10. Supported OCP cards

Form factor	Vendor	Port type	Port speed	Port count
OCP 3.0	Intel	SFP28	25 GbE	4
	Broadcom	SFP28	25 GbE	4
	Intel	SFP28	25 GbE	2
	Broadcom	SFP28	25 GbE	2
	Broadcom	BT	10 GbE	4
	Intel	BT	10 GbE	2

Table 10. Supported OCP cards (continued)

Form factor	Vendor	Port type	Port speed	Port count
	Intel	BT	10 GbE	4
	Broadcom	BT	1 GbE	4
	Intel	BT	1 GbE	4

OCP NIC 3.0 vs. rack Network Daughter Card comparisons

Table 11. OCP 3.0, 2.0, and rNDC NIC comparison

Form Factor	Dell rNDC	OCP 2.0 (LOM Mezz)	OCP 3.0	Notes
PCIe Gen	Gen 3	Gen 3	Gen 4	Supported OCP3 are SFF (small form factor)
Max PCIe Lanes	x8	Up to x16	Up to x8	See server slot priority matrix
Shared LOM	Yes	Yes	Yes	This is iDRAC port redirect
Aux Power	Yes	Yes	Yes	Used for Shared LOM

PCIe subsystem

The R660 supports up to 3 x16 low profile slots by riser2 and riser3. All PCIe ports are 75W card edge delivered power per slot.

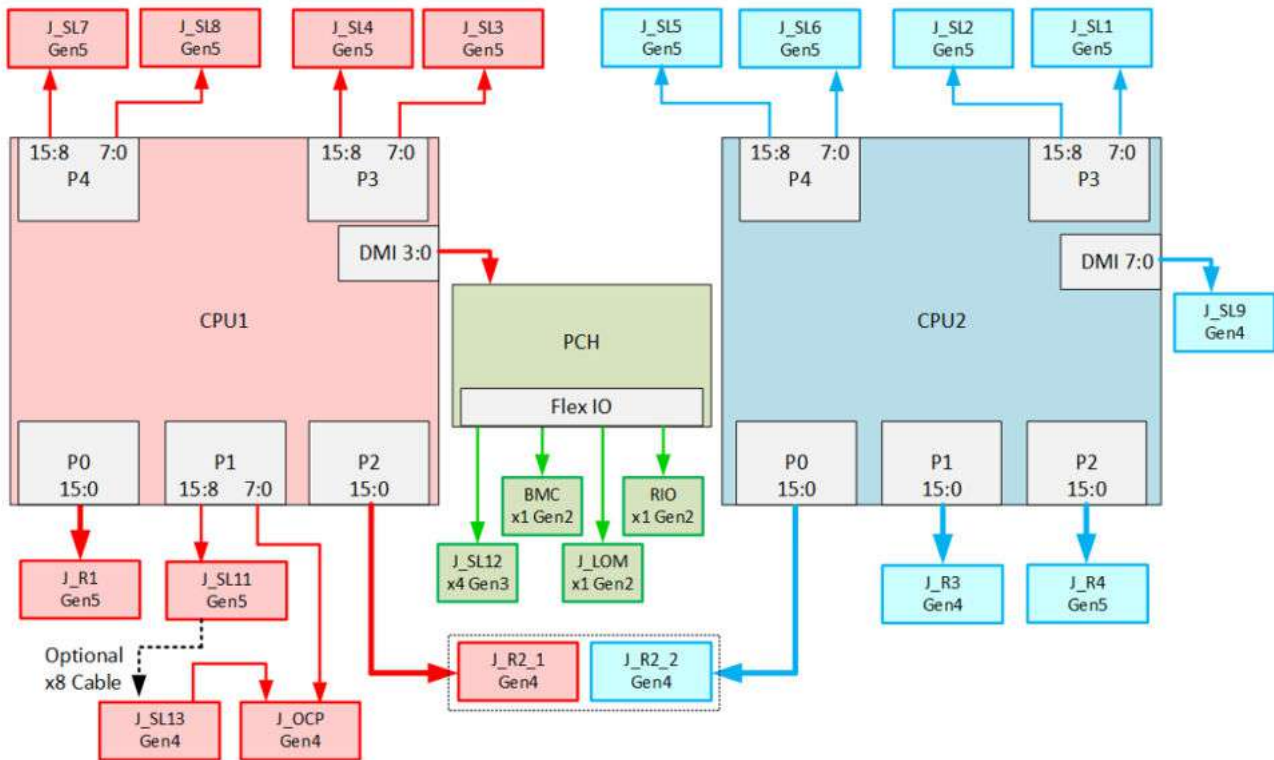

Figure 8. PCIe connection diagram

Topics:

- PCIe risers

PCIe risers

The PowerEdge R660 have a no riser option. Shown below are the riser offerings for the PowerEdge R660.

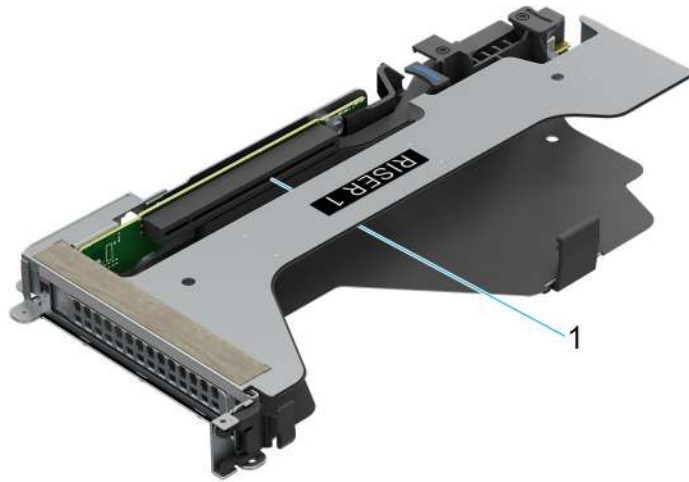

Figure 9. Riser 1P

1. Slot 1

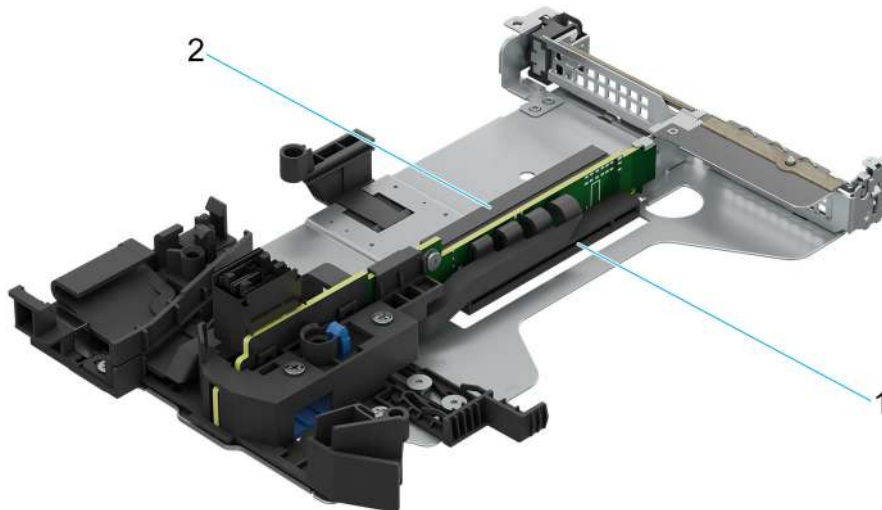

Figure 10. Riser 2P

1. Slot 1
2. Slot 2

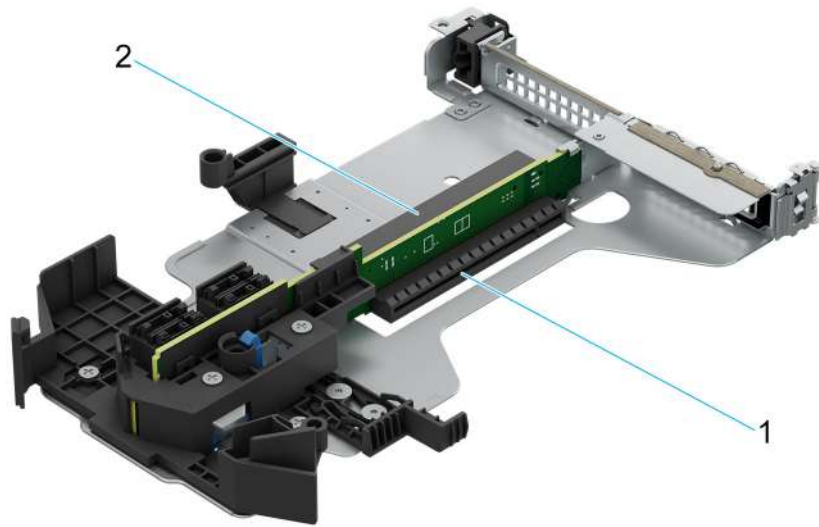

Figure 11. Riser 2A

- 1. Slot 1
- 2. Slot 2

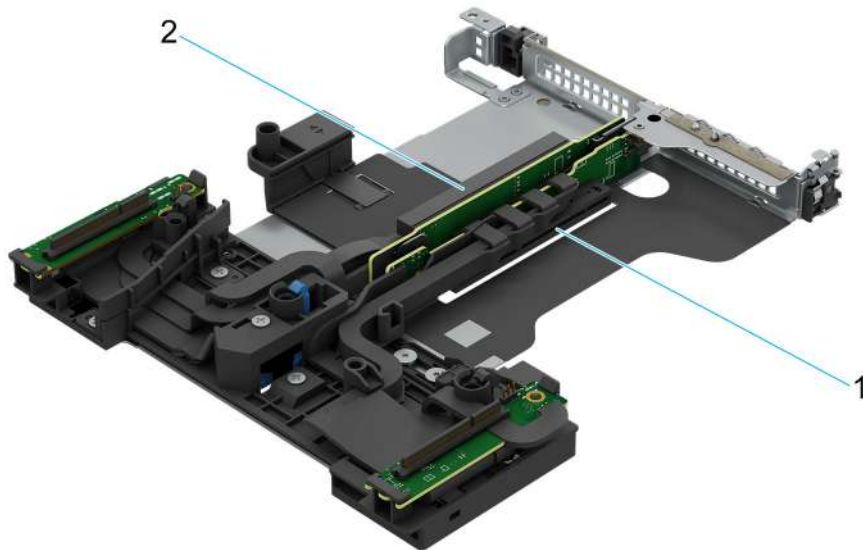

Figure 12. Riser 2Q

- 1. Slot 1
- 2. Slot 2



Figure 13. Riser 3P

- 1. Slot 3

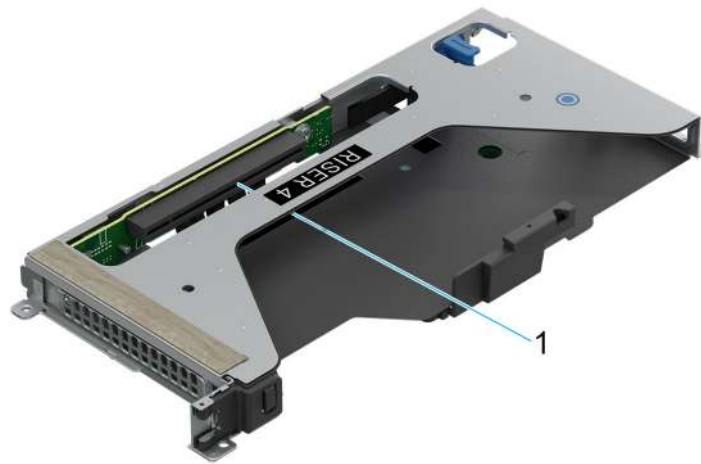

Figure 14. Riser 4P

- 1. Slot 2



Figure 15. Riser 2R

1. Slot 1

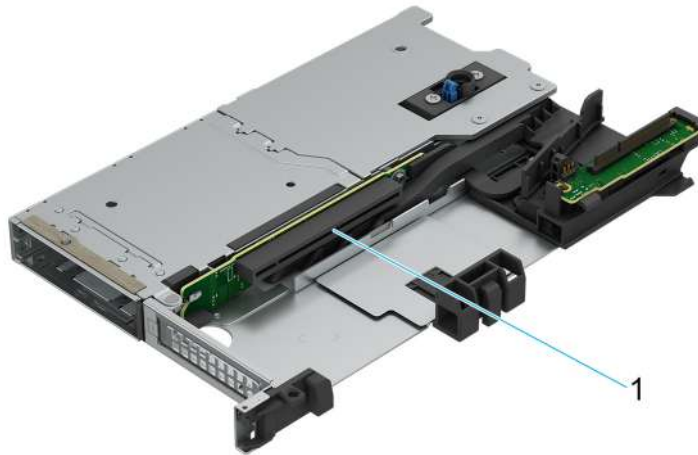

Figure 16. Riser 2S

1. Slot 1



Figure 17. Riser 3Q

1. Slot 3

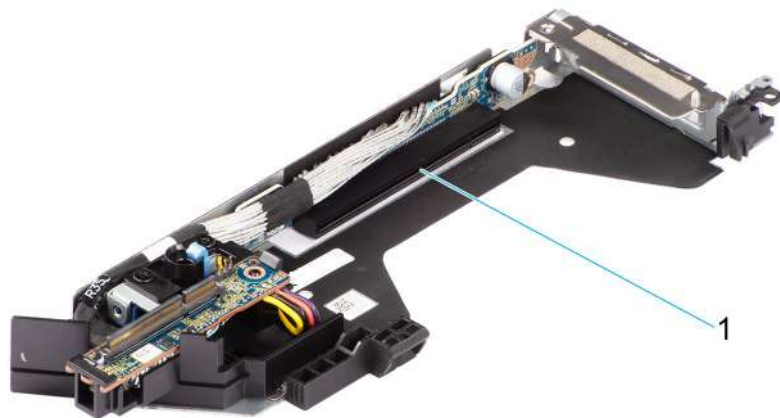

Figure 18. Riser 3S

1. Slot 3



Figure 19. Riser 3R

1. Slot 3

Table 12. PCIe Riser Configuration

Config No.	Riser configuration	No. of Processors	PERC type supported	Rear Storage Possible
0	No RSR	2	Front PERC	No
1	R2A+R3A	2	Front PERC / PERC Adapter	No
2	R2P+R3P	2	Front PERC	No
3	R1P+R4P	2	Front PERC / PERC Adapter	No
4	R2R+R3R	1	N/A	No
5	R2A+R3Q	2	Front PERC / PERC Adapter	No
6-1	R2Q (non A2)	2	Front PERC	No
6 -2	R2Q (only for A2)	2	Front PERC	No
7	R3P	2	Front PERC	Yes
8	R2A	1	Front PERC / PERC Adapter	No

Power, thermal, and acoustics

PowerEdge servers have an extensive collection of sensors that automatically track thermal activity, which helps regulate temperature thereby reducing server noise and power consumption. The table below lists the tools and technologies Dell offers to lower power consumption and increase energy efficiency.

Topics:

- [Power](#)
- [Thermal](#)
- [Acoustics](#)

Power

Table 13. Power tools and technologies

Feature	Description
Power Supply Units(PSU) portfolio	Dell's PSU portfolio includes intelligent features such as dynamically optimizing efficiency while maintaining availability and redundancy. Find additional information in the Power supply units section.
Tools for right sizing	Enterprise Infrastructure Planning Tool (EIPT) is a tool that can help you determine the most efficient configuration possible. With Dell's EIPT, you can calculate the power consumption of your hardware, power infrastructure, and storage at a given workload. Learn more at www.dell.com/calc .
Industry Compliance	Dell's servers are compliant with all relevant industry certifications and guide lines, including 80 PLUS, Climate Savers and ENERGY STAR.
Power monitoring accuracy	PSU power monitoring improvements include: <ul style="list-style-type: none"> • Dell's power monitoring accuracy is currently 1%, whereas the industry standard is 5% • More accurate reporting of power • Better performance under a power cap
Power capping	Use Dell's systems management to set the power cap limit for your systems to limit the output of a PSU and reduce system power consumption. Dell is the first hardware vendor to leverage Intel Node Manager for circuit-breaker fast capping.
Systems Management	iDRAC Enterprise and Datacenter provides server-level management that monitors, reports and controls power consumption at the processor, memory and system level. Dell OpenManage Power Center delivers group power management at the rack, row, and data center level for servers, power distribution units, and uninterruptible power supplies.
Active power management	Intel Node Manager is an embedded technology that provides individual server-level power reporting and power limiting functionality. Dell offers a complete power management solution comprised of Intel Node Manager accessed through Dell iDRAC9 Datacenter and OpenManage Power Center that allows policy-based management of power and thermal at the individual server, rack, and data center level. Hot spare reduces power consumption of redundant power supplies. Thermal control off a speed optimizes the thermal settings for your environment to reduce fan consumption and lower system power consumption. Idle power enables Dell servers to run as efficiently when idle as when at full workload.
Fresh Air cooling	Refer to ASHRAE A3/A4 Thermal Restriction.

Table 13. Power tools and technologies (continued)

Feature	Description
Rack infrastructure	<p>Dell offers some of the industry's highest-efficiency power infrastructure solutions, including:</p> <ul style="list-style-type: none"> • Power distribution units (PDUs) • Uninterruptible power supplies (UPSs) • Energy Smart containment rack enclosures <p>Find additional information at: https://www.delltechnologies.com/en-us/servers/power-and-cooling.htm.</p>

Power Supply Units

Energy Smart power supplies have intelligent features, such as the ability to dynamically optimize efficiency while maintaining availability and redundancy. Also featured are enhanced power-consumption reduction technologies, such as high-efficiency power conversion and advanced thermal-management techniques, and embedded power-management features, including high-accuracy power monitoring. The table below shows the power supply unit options that are available for the R660.

Table 14. Power Supply Unit Options

Wattage	Frequency	Voltage/Current	Class	Heat dissipation
700 W mixed mode	50/60Hz	200-240 V AC/4.1 A	Titanium	2625 BTU/hr
	N/A	240 V DC/3.4 A	N/A	2625 BTU/hr
800 W mixed mode	50/60Hz	100-240 V AC/ 9.2-4.7 A	Platinum	3000 BTU/hr
	N/A	240 V DC/3.8 A	N/A	3000 BTU/hr
1100 W mixed mode	50/60 Hz	100-240 V AC/ 12-3.6 A	Titanium	4100 BTU/hr
	N/A	240 V DC/5.2 A	N/A	4100 BTU/hr
1100 W -48 VDC	N/A	-48 - -60 V DC/27A	N/A	4625 BTU/hr
1400 W mixed mode	50/60 Hz	100-240 V AC/ 12-8 A	Platinum	5250 BTU/hr
	N/A	240 V DC/6.6 A	N/A	5250 BTU/hr
1800 W mixed mode	50/60 Hz	200-240 V AC/10 A	Titanium	6610 BTU/hr
	N/A	240 V DC/8.2 A	N/A	6610 BTU/hr

NOTE: If a system with AC 1400 W or 1100 W PSUs operates at low line 100-120 Vac, and then the power rating per PSU is degraded to 1050 W.



Figure 20. PSU power cords

Table 15. PSU power cords

Form factor	Output	Power cord
Redundant 60 mm	700 W AC	C13
	800 W AC	C13
	1100 W AC	C13

Table 15. PSU power cords (continued)

Form factor	Output	Power cord
	1100 W -48 V DC	C13
	1400 W AC	C13
	1800 W AC	C15

NOTE: C13 power cord combined with C14 to C15 jumper power cord can be used to adapt 1800 W PSU.

Thermal

PowerEdge servers have an extensive collection of sensors that automatically track thermal activity, which helps regulate temperature thereby reducing server noise and power consumption.

Thermal design

Thermal management of the platform helps deliver high performance with the right amount of cooling to components, while maintaining the lowest fan speeds possible. This is done across a wide range of ambient temperatures from 10°C to 35°C (50°F to 95°F) and to extended ambient temperature ranges.

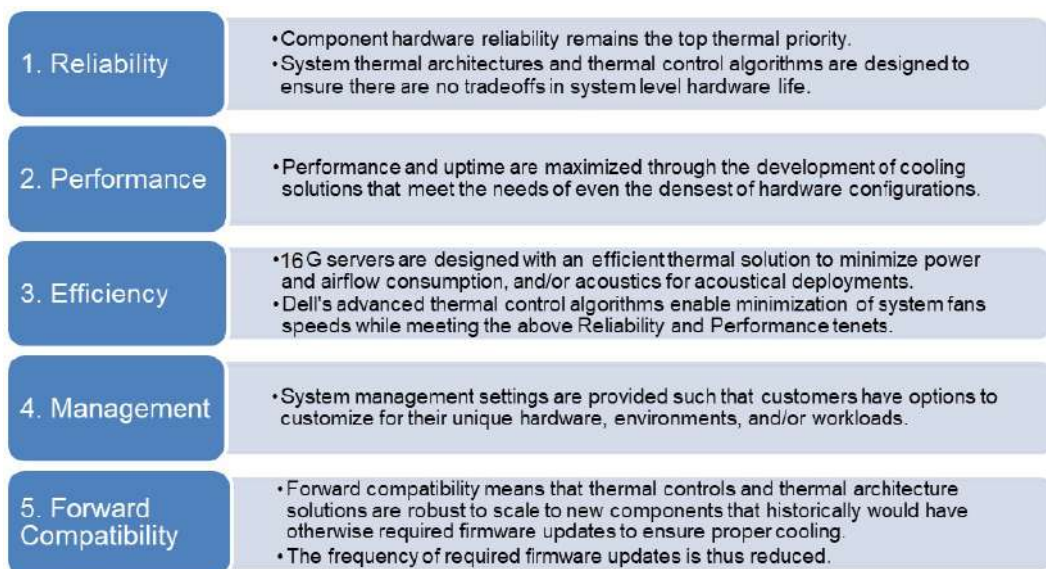

Figure 21. Thermal design characteristics

The thermal design of the PowerEdge R660 reflects the following:

- Optimized thermal design: The system layout is architected for optimum thermal design.
- System component placement and layout are designed to provide maximum airflow coverage to critical components with minimum expense of fan power.
- Comprehensive thermal management: The thermal control system regulates the fan speed based on several different responses from all system-component temperature sensors, as well as inventory for system configurations. Temperature monitoring includes components such as processors, DIMMs, chipset, the inlet air ambient, hard disk drives, and OCP.
- Open and closed loop thermal fan speed control: Open loop thermal control uses system configuration to determine fan speed based on inlet air ambient temperature. Closed loop thermal control method uses feedback temperatures to dynamically determine proper fan speeds.
- User-configurable settings: With the understanding and realization that every customer has unique set of circumstances or expectations from the system, in this generation of servers, we have introduced limited user-configurable settings residing in the iDRAC BIOS setup screen. For more information, see the Dell PowerEdge R660 Installation and Service Manual at www.dell.com/poweredgemanuals and "Advanced Thermal Control: Optimizing across Environments and Power Goals" on Dell.com.

- Cooling redundancy: The R660 allows N+1 fan redundancy, allowing continuous operation with one fan failure in the system.
- Environmental Specifications: The optimized thermal management makes the R660 reliable under a wide range of operating environments.

Acoustics

Acoustical performance

Dell PowerEdge R660 is a rack-mount server appropriate for attended data center environment. However, lower acoustical output is attainable with proper hardware or software configurations.

Table 16. Acoustical Configurations of R660

Configuration	Volume - 1 (HPC)	Margin Rich
Acoustical Category	Category 4	Category 5
CPU TDP	165 W	300 W
CPU Quantity	2	2
Memory Type	64 GB DDR5 RDIMM	128 GB DDR5 RDIMM
DIMM Quantity	16	32
Backplane Type	10 x 2.5 inches	10 x 2.5 inches
HDD Type	2.5 inches NVMe SSD	2.5 inches NVMe SSD
HDD Quantity	10	10
PSU Type	1400 W	1400 W
PSU Quantity	2	2
PCI 1	Dual Port 25 GbE	N/A
PCI 2	Dual Port 25 GbE	N/A
Front PERC	N/A	N/A
OCP	Dual Port 25GbE	Dual Port 200GbE
M.2	Boss-N1	BOSS-N1

Table 17. Acoustical experience of R660 configurations

Configuration	Volume - 1 (HPC)	Feature Rich	
Acoustical Performance: Idle/ Operating @ 25°C Ambient			
L _{WA,m} (B)	Idle ⁽⁴⁾	5.3	6.4
	Operating/Customer usage operating ⁽⁵⁾ (6)	5.3	6.5
K _v (B)	Idle ⁽⁴⁾	0.4	0.4
	Operating/Customer usage operating ⁽⁵⁾ (6)	0.4	0.4
L _{pA,m} (dB)	Idle ⁽⁴⁾	41.3	52.3
	Operating/Customer usage operating ⁽⁵⁾ (6)	41.3	52.5
Prominent tones ⁽³⁾ Acoustical Performance: Idle @ 28°C Ambient			
L _{WA,m} ⁽¹⁾ (B)	1/6~1/13	7.0	

Table 17. Acoustical experience of R660 configurations (continued)

Configuration	Volume - 1 (HPC)	Feature Rich
K_v (B)	0.4	0.4
$L_{pA,m}^{(2)}$ (dB)	1/6~1/13	55.4
Acoustical Performance: Max. loading @ 35°C Ambient		
$L_{wA,m}^{(1)}$ (B)	1/6~1/13	8.5
K_v (B)	0.4	0.4
$L_{pA,m}^{(2)}$ (dB)	1/6~1/13	72.2

⁽¹⁾ $L_{wA,m}$: The declared mean A-weighted sound power level (L_{wA}) is calculated per section 5.2 of ISO 9296 (2017) with data collected using the methods that are described in ISO 7779 (2010). Engineering data presented here may not be fully compliant with ISO 7779 declaration requirement.

⁽²⁾ $L_{pA,m}$: The declared mean A-weighted emission sound pressure level is at the bystander position per section 5.3 of ISO 9296 (2017) and measured using methods that are described in ISO 7779 (2010). The system is placed in a 24U rack enclosure, 75 cm above a reflective floor. Engineering data presented here may not be fully compliant with ISO 7779 declaration requirement.

⁽³⁾Prominent tones: Criteria of Annex D of ECMA-74 and Prominence Ratio method of ECMA-418 are followed to determine if discrete tones are prominent and to report them, if so.

⁽⁴⁾Idle mode: The steady-state condition in which the server is energized but not operating any intended function.

⁽⁵⁾Operating mode: The maximum of the steady state acoustical output at 50% of CPU TDP or active storage drives for the respective sections of Annex C of ECMA-74.

⁽⁶⁾ Customer Usage Operating mode: The operating mode is represented by the maximum of the steady state acoustical output at 25%~30% of CPU TDP, 2.5%~10% IOPs load, and >80% GPU load as the components showed in the above configurations.

PowerEdge acoustical specifications

For more information on acoustical specifications, see ENG0019663. (See the category definitions.)

Dell typically categorizes servers in five categories of acoustically acceptable usage:

- Category 1: Table-top in Office Environment
- Category 2: Floor-standing in Office Environment
- Category 3: General Use Space
- Category 4: Attended Data Center
- Category 5: Unattended Data Center

Category 2: Floor-standing in Office Environment

When Dell determines that a specific Enterprise product is to be used primarily when it is sitting on the floor, that is, next to a user's feet, then the acoustical specification in the table below applies. Noise from the product should not annoy or otherwise interfere with the user's thoughts or speech, for example, on the telephone.

Table 18. Dell Enterprise Category 2, “Floor-standing in Office Environment” acoustical specification category

Measurement Position re AC0158	Metric, re AC0159	Test Modes, re AC0159 (note must be in steady state, see AC0159, except where noted below)			
		Standby in 23±2° C Ambient	Idle in 23±2° C Ambient	Operating in 23±2° C Ambient – if not otherwise specified in the program’s configuration document, then processor and hard drive operating modes are required	Simulate (that is, set fan speeds representative) for Idle at 28° C & 35° C Ambient, and for 100% loading and maximum configuration, at 35° C Ambient
Sound Power	LWA,m, B	≤ 4.9	≤ 5.1	≤ 5.4	Report
Sound Quality (both positions must meet limits): Front Binaural HEAD and Rear Microphone	Tones, Hz, dB	No prominent tones per criteria D.10.6 and D.10.8 of ECMA-74			Report tones
	Tonality, tu	≤ 0.35	≤ 0.35	≤ 0.35	Report
	Dell Modulation, %	≤ 35	≤ 35	≤ 35	Report
	Loudness, sones	Report	Report	Report	Report
	LpA-single point, dBA	Report	Report	Report	Report
Front Binaural HEAD	Transients	<ul style="list-style-type: none"> • Oscillation (see AC0159), if observed, during 20-minute steady-state observation, must adhere to the following two criteria: <ul style="list-style-type: none"> ◦ Max. {ΔLpA} < 3.0 dB ◦ Event count < 3 for “1.5 dB < ΔLpA < 3.0 dB” • Acoustical Jump (see AC0159), during air mover speed transition from Idle to Operating Mode must be ≤ 15 dB. • Startup behavior <ul style="list-style-type: none"> ◦ Report Startup behavior re. AC0159 ◦ Startup must proceed smoothly, that is, no sudden or large jumps, and fan speed during startup must not exceed 50% of its maximum • Transient inputs: Report time-history sound pressure levels re AC0159 “Train of Step Functions on Processor” 			N/A
Any	Other	<ul style="list-style-type: none"> • No rattles, squeaks, or unexpected noises • Sound should be “even” around the EUT (one side should not be dramatically louder than another) • Unless otherwise specified, the “default” thermal-related settings shall be selected for BIOS and iDRAC. • Specific operating conditions are defined in “Configurations and Configuration Dependencies” for each platform. 			
Sound Pressure	LpA-reported, dBA, re AC0158 and program configuration document	Report for all mics	Report for all mics	Report for all mics	Report for all mics

Category 4: Attended Data Center

When Dell determines that a specific Enterprise product is to be predominantly used in an attended data center, then the acoustical specification of the table applies. The phrase “attended data center” is used to mean a space in which many (from tens to 1000s) of Enterprise products are deployed in proximity (that is, in the same room) to personnel whose speech (perhaps with raised voices) is expected to be intelligible over the data center noise. Hearing protection or hearing monitoring programs are not expected in these areas. Examples in this category include monolithic rack products. When Dell determines that a specific Enterprise product is to be predominantly used in a general use space, then the acoustical specification of the above table applies. These products could be found in laboratories, schools, restaurants, open office space layouts, small ventilated closets, etc., though not in close proximity to any particular person nor in quantities greater than a few in any location. People within proximity of a few of these products should not experience any impact to speech intelligibility or annoyance from the noise of the product. A rack product sitting on a table in a common area is an example.

Table 19. Dell Enterprise Category 4, “Attended Data Center” acoustical specification category.

Measurement Position re AC0158	Metric, re AC0159	Test Modes, re AC0159 (note must be in steady state, see AC0159, except where noted below)				Simulate (that is, set fan speeds representative) for 100% loading and maximum configuration, at 35° C Ambient
		Standby in 23±2° C Ambient	Idle in 23±2° C Ambient	Operating in 23±2° C Ambient – if not otherwise specified in the program’s configuration document, then processor and hard drive operating modes are required	Simulate (that is, set fan speeds representative) for Idle at 28° C & 35° C Ambient	
Sound Power	LWA,m, B	Report	≤ 6.9	≤ 7.1	Report	≤ 8.5
Front Binaural HEAD	Tones, Hz, dB	Report	< 15 dB	< 15 dB	Report	< 20 dB
	Tonality, tu	Report	Report	Report	Report	Report
	Dell Modulation, %	Report	Report	Report	Report	Report
	Loudness, sones	Report	Report	Report	Report	Report
	LpA-single point, dBA	Report	Report	Report	Report	Report
	Transients	<ul style="list-style-type: none"> ● Oscillation (see AC0159), if observed, during 20-minute steady-state observation, must adhere to the following two criteria: <ul style="list-style-type: none"> ○ Max. {ΔLpA} < 3.0 dB ○ Event count < 3 for “1.5 dB < ΔLpA < 3.0 dB” ○ Acoustical Jump (see AC0159), during air mover speed transition from Idle to Operating Mode must be ≤ 15 dB. ○ Startup behavior <ul style="list-style-type: none"> ■ Report Startup behavior re. AC0159 ■ Startup must proceed smoothly, that is, no sudden or large jumps, and fan speed during startup must not exceed 50% of its maximum ∞ Transient inputs: Report time-history sound pressure levels re AC0159 “Train of Step Functions on Processor” 	N/A			
Any	Other	No rattles, squeaks, or unexpected noises Sound should be “even” around the EUT (one side should not be dramatically louder than another)				

Table 19. Dell Enterprise Category 4, “Attended Data Center” acoustical specification category. (continued)

Measurement Position re AC0158	Metric, re AC0159	Test Modes, re AC0159 (note must be in steady state, see AC0159, except where noted below)				Simulate (that is, set fan speeds representative) for 100% loading and maximum configuration, at 35° C Ambient
		Standby in 23±2° C Ambient	Idle in 23±2° C Ambient	Operating in 23±2° C Ambient – if not otherwise specified in the program’s configuration document, then processor and hard drive operating modes are required	Simulate (that is, set fan speeds representative) for Idle at 28° C & 35° C Ambient	
		Unless otherwise specified, the “default” thermal-related settings shall be selected for BIOS and iDRAC. Specific operating conditions will be defined in “Configurations & Configuration Dependencies” for each platform.				
Sound Pressure	LpA-reported, dBA	Report for all mics	Report for all mics	Report for all mics	Report for all mics	Report for all mics

Category 5: Unattended Data Center

When Dell determines that a specific Enterprise product is to be predominantly used in an unattended data center (and not blades or blade enclosures; these have their own category), then the acoustical specification in the table below applies. The phrase “unattended data center” is used to mean a space in which many (from tens to 1000s) of Enterprise products are deployed together, its own heating and cooling systems condition the space, and operators or servicers of equipment enter generally only to deploy, service, or decommission equipment. Hearing protection or hearing monitoring programs may be expected (per government or company guidelines) in these areas. Examples in this category include monolithic rack products.

Table 20. Dell Enterprise Category 5, “Unattended Data Center” acoustical specification category

Measurement Position re AC0158	Metric, re AC0159	Test Modes, re AC0159 (note must be in steady state, see AC0159, except where noted below)				Simulate (that is, set air mover speeds representative) for 100% loading and maximum configuration, at 35° C Ambient
		Standby in 23±2° C Ambient	Idle in 23±2° C Ambient	Operating in 23±2° C Ambient – if not otherwise specified in the program’s configuration document, then processor and hard drive operating modes are required	Simulate (that is, set air mover speeds representative) for Idle at 28° C & 35° C Ambient	
Sound Power	LWA,m, B	Report	≤ 7.5	≤ 7.7	Report	≤ 8.7
Front Binaural HEAD	Tones, Hz, dB	Report	< 15 dB	< 15 dB	Report	< 20 dB
	Tonality, tu	Report	Report	Report	Report	Report
	Dell Modulation, %	Report	Report	Report	Report	Report

Table 20. Dell Enterprise Category 5, “Unattended Data Center” acoustical specification category (continued)

Measurement Position re AC0158	Metric, re AC0159	Test Modes, re AC0159 (note must be in steady state, see AC0159, except where noted below)				Simulate (that is, set air mover speeds representative) for 100% loading and maximum configuration, at 35° C Ambient
		Standby in 23±2° C Ambient	Idle in 23±2° C Ambient	Operating in 23±2° C Ambient – if not otherwise specified in the program’s configuration document, then processor and hard drive operating modes are required	Simulate (that is, set air mover speeds representative) for Idle at 28° C & 35° C Ambient	
	Loudness, sones	Report	Report	Report	Report	Report
	LpA-single point, dBA	Report	Report	Report	Report	Report
Front Binaural HEAD	Transients	<ul style="list-style-type: none"> Oscillation (see AC0159), if observed, during 20-minute steady-state observation, must adhere to the following two criteria: <ul style="list-style-type: none"> Max. {ΔLpA} < 3.0 dB Event count < 3 for “1.5 dB < ΔLpA < 3.0 dB” Report Acoustical Jump (see AC0159) during air mover speed transition from Idle to Operating Mode. Startup behavior <ul style="list-style-type: none"> Report Startup behavior re. AC0159 Startup must proceed smoothly, that is, no sudden or large jumps, and air mover speed during startup must not exceed 50% of its maximum Transient inputs: Report time-history sound pressure levels re AC0159 “Train of Step Functions on Processor” 			N/A	
Any	Other	<p>No rattles, squeaks, or unexpected noises</p> <p>Sound should be “even” around the EUT (one side should not be dramatically louder than another)</p> <p>Unless otherwise specified, the “default” thermal-related settings shall be selected for BIOS and iDRAC.</p> <p>Specific operating conditions will be defined in “Configurations & Configuration Dependencies” for each platform.</p>				
Sound Pressure	LpA-reported, dBA, re AC0158 and program configuration document	Report for all mics	Report for all mics	Report for all mics	Report for all mics	Report for all mics

Rack, rails, and cable management

Topics:

- [Rails and cable management information](#)

Rails and cable management information

The rail offerings for the PowerEdge R660 consist of two general types: sliding and static. The cable management offerings consist of an optional cable management arm (CMA) and an optional strain relief bar (SRB).

See the *Dell Technologies Enterprise Systems Rail Sizing and Rack Compatibility Matrix* available at https://i.dell.com/sites/csdocuments/Business_solutions_engineering-Docs_Documents/en/rail-rack-matrix.pdf for information regarding:

- Specific details about rail types.
- Rail adjustability ranges for various rack mounting flange types.
- Rail depth with and without cable management accessories.
- Rack types that are supported for various rack mounting flange types.

Key factors governing proper rail selection include the following:

- Spacing between the front and rear mounting flanges of the rack.
- Type and location of any equipment that is mounted in the back of the rack such as power distribution units (PDUs).
- Overall depth of the rack

Sliding rails features summary

The sliding rails allow the system to be fully extended out of the rack for service. There are two types of sliding rails available, ReadyRails II sliding rails and Stab-in/Drop-in sliding rails. The sliding rails are available with or without the optional cable management arm (CMA) or strain relief bar (SRB).

A15 ReadyRails II sliding rails for 4-post racks

- Supports drop-in installation of the chassis to the rails.
 - Support for tool-less installation in 19" EIA-310-E compliant square or un-threaded round hole 4-post racks including all generations of the Dell racks.
 - Support for tooled installation in 19" EIA-310-E compliant threaded hole 4-post racks.
 - Support full extension of the system out of the rack to allow serviceability of key internal components.
 - Support for optional strain relief bar (SRB).
 - Support for optional cable management arm (CMA).
- NOTE:** For situations where CMA support is not required, the outer CMA mounting brackets can be uninstalled from the sliding rails. This reduces the overall length of the rails and eliminates the potential interferences with rear mounted PDUs or the rear rack door.

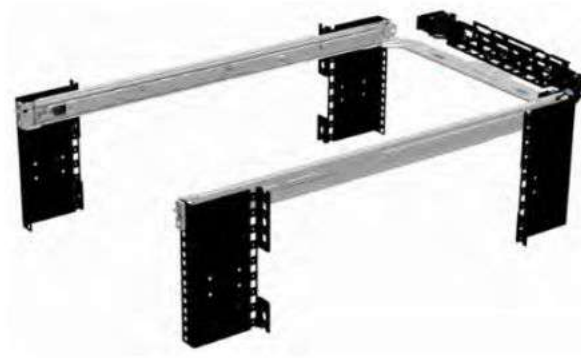

Figure 22. Sliding rails with optional CMA



Figure 23. Sliding rails with optional SRB

A16 Stab-in/Drop-in sliding rails for 4-post racks

- Supports drop-in or stab-in installation of the chassis to the rails.
- Support for tool-less installation in 19" EIA-310-E compliant square, un-threaded round hole racks including all generations of the Dell racks. Also supports tool-less installation in threaded round hole 4-post racks.
- Support for tool-less installation in Dell Titan or Titan-D racks
- Support full extension of the system out of the rack to allow serviceability of key internal components.
- Support for optional cable management arm (CMA).
- Support for optional strain relief bar (SRB).

NOTE: For situations where CMA support is not required, the outer CMA mounting brackets can be uninstalled from the sliding rails. This reduces the overall length of the rails and eliminates the potential interferences with rear mounted PDUs or the rear rack door.

Scan the QRL code for the documentation and trouble-shooting information regarding the installation procedures for Drop-in/Stab-in rail types.



Figure 24. Quick resource locator for combo rails

A14 static rails summary

The static rails offer a greater adjustability range and a smaller overall mounting footprint than the sliding rails because of their reduced complexity and lack of need for CMA support. The static rails support a wider variety of racks than the sliding rails. However, they do not support serviceability in the rack and are thus not compatible with the CMA. The static rails are also not compatible with SRB.



Figure 25. Static rails

Static rails features summary

Static rails for 4-post and 2-post racks:

- Supports Stab-in installation of the chassis to the rails.
- Support tool-less installation in 19" EIA-310-E compliant square or un-threaded round hole 4-post racks including all generations of Dell racks.
- Support tooled installation in 19" EIA-310-E compliant threaded hole 4-post and 2-post racks.
- Support for tooled installation in Dell Titan or Titan-D rack.

NOTE:

- Screws are not included with the static rail kit since racks are offered with various thread types. The screws are provided for mounting static rails in racks with threaded mounting flanges.
- Screw head diameter should be 10 mm or less.

2-Post racks installation

If installing to 2-Post (Telco) racks, the ReadyRails II static rails (A14) must be used. Sliding rails support mounting in 4-post racks only.



Figure 26. Static rails in 2-post center mount configuration

Installation in the Dell Titan or Titan-D racks

For tool-less installation in Titan or Titan-D racks, the Stab-in/Drop-in sliding rails (A16) must be used. This rail collapses down sufficiently to fit in the rack with mounting flanges that are spaced about 24 inches apart from front to back. The Stab-in/Drop-in sliding rail allows bezels of the servers and storage systems to be aligned when installed in these racks. For tooled installation, Stab-in static rails (A14) must be used for bezel alignment with storage systems.

Cable management arm (CMA)

The optional cable management arm (CMA) organizes and secures the cords and cables exiting the back of the systems. It unfolds to allow the systems to extend out of the rack without having to detach the cables. Some key features of the CMA include:

- Large U-shaped baskets to support dense cable loads.
- Open vent pattern for optimal airflow.
- Ability to mount on either side by swinging the spring-loaded brackets from one side to the other.
- Utilizes hook-and-loop straps rather than plastic tie wraps to eliminate the risk of cable damage during cycling.
- Includes a low-profile fixed tray to both support and retain the CMA in its fully closed position.
- Both the CMA and the tray mount without the use of tools by simple and intuitive snap-in designs.
- CMA is not supported in Direct Liquid Cooling (DLC) configuration.

The CMA can be mounted to either side of the sliding rails without the use of tools or the need for conversion. For systems with one power supply unit (PSU), it is recommended to mount on the side opposite to that of the power supply to allow easier access to it and the rear drives (if applicable) for service or replacement.

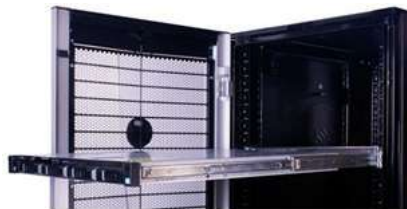

Figure 27. Sliding rails with CMA



Figure 28. CMA Cabling

Strain Relief Bar (SRB)

The optional strain relief bar (SRB) for the PowerEdge R660 organizes and supports cable connections at the rear end of the server to avoid damage from bending.

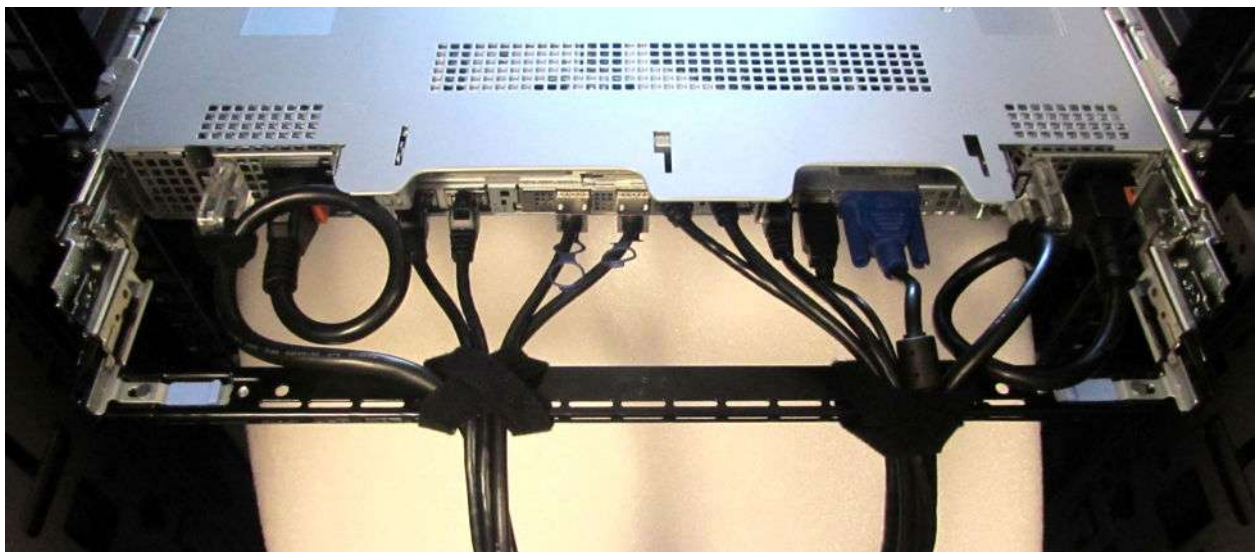

Figure 29. Cabled strain relief bar

- Tool-less attachment to the rails
- Two depth positions to accommodate various cable loads and rack depths
- Supports cable loads and controls stresses on server connectors
- Cables can be segregated into discrete purpose-specific bundles

Rack Installation

Drop-in design means that the system is installed vertically into the rails by inserting the standoffs on the sides of the system into the J-slots in the inner rail members with the rails in the fully extended position. The recommended method of installation is to first insert the rear standoffs on the system into the rear J-slots on the rails to free up a hand and then rotate the system down into the remaining J-slots while using the free hand to hold the rail against the side of the system.

Stab-in design means that the inner (chassis) rail members must first be attached to the sides of the system and then inserted into the outer (cabinet) members installed in the rack.

Installing system into the rack (option A: Drop-In)

1. Pull the inner rails out of the rack until they lock into place.



Figure 30. Pull out inner rail

2. Locate the rear rail standoff on each side of the system and lower them into the rear J-slots on the slide assemblies.
3. Rotate the system downward until all the rail standoffs are seated in the J-slots.

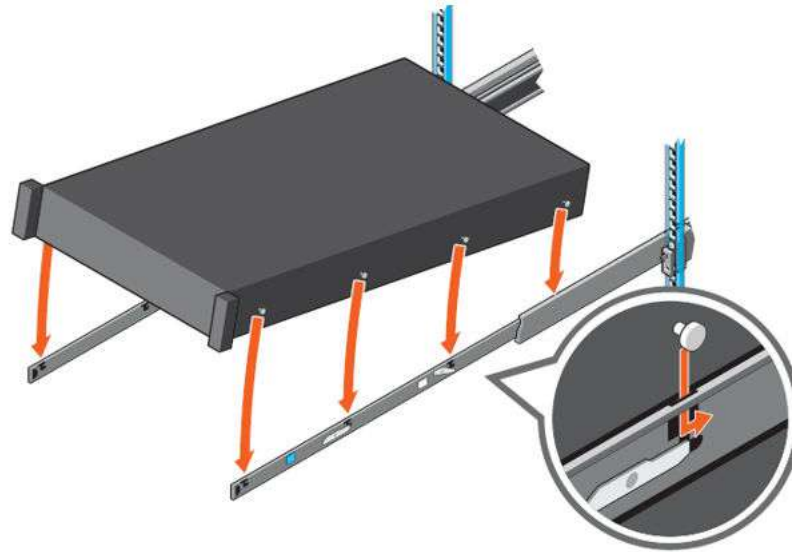

Figure 31. Rail standoffs seated in J-slots

4. Push the system inward until the lock levers click into place.
5. Pull the blue side release lock tabs forward or backward on both rails and slide the system into the rack until the system is in the rack.

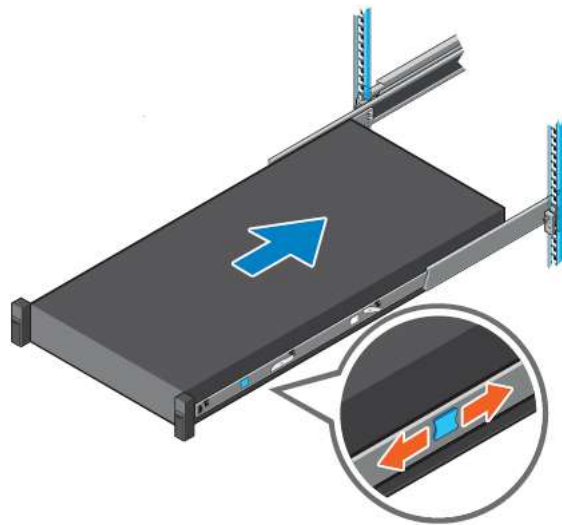

Figure 32. Slide system into the rack

Installing the system into the rack (option B: Stab-In)

1. Pull the intermediate rails out of the rack until they lock into place.
2. Release the inner rail lock by pulling forward on the white tabs and sliding the inner rail out of the intermediate rails.

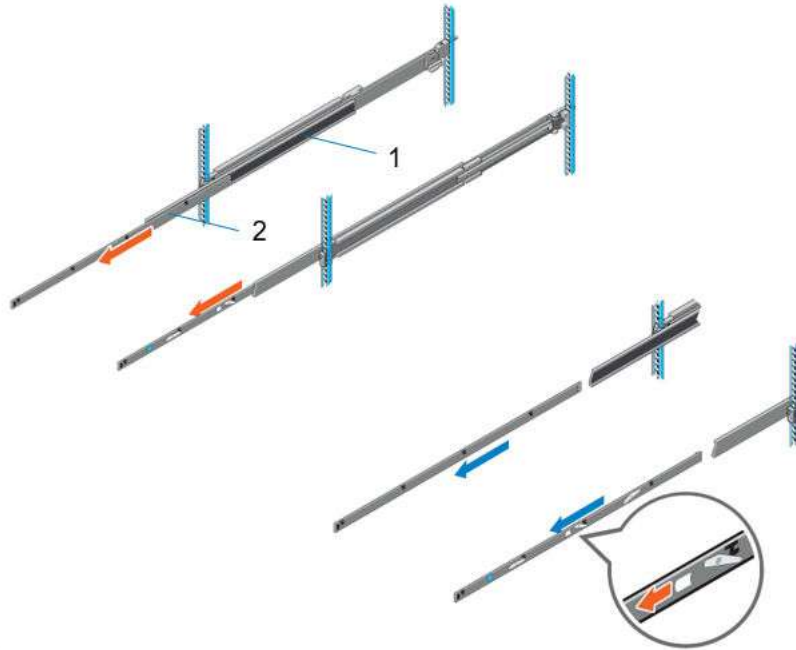

Figure 33. Pull out the intermediate rail

Table 21. Rail component label

Number	Component
1	Intermediate rail
2	Inner rail

3. Attach the inner rails to the sides of the system by aligning the J-slots on the rail with the standoffs on the system and sliding forward on the system until they lock into place.

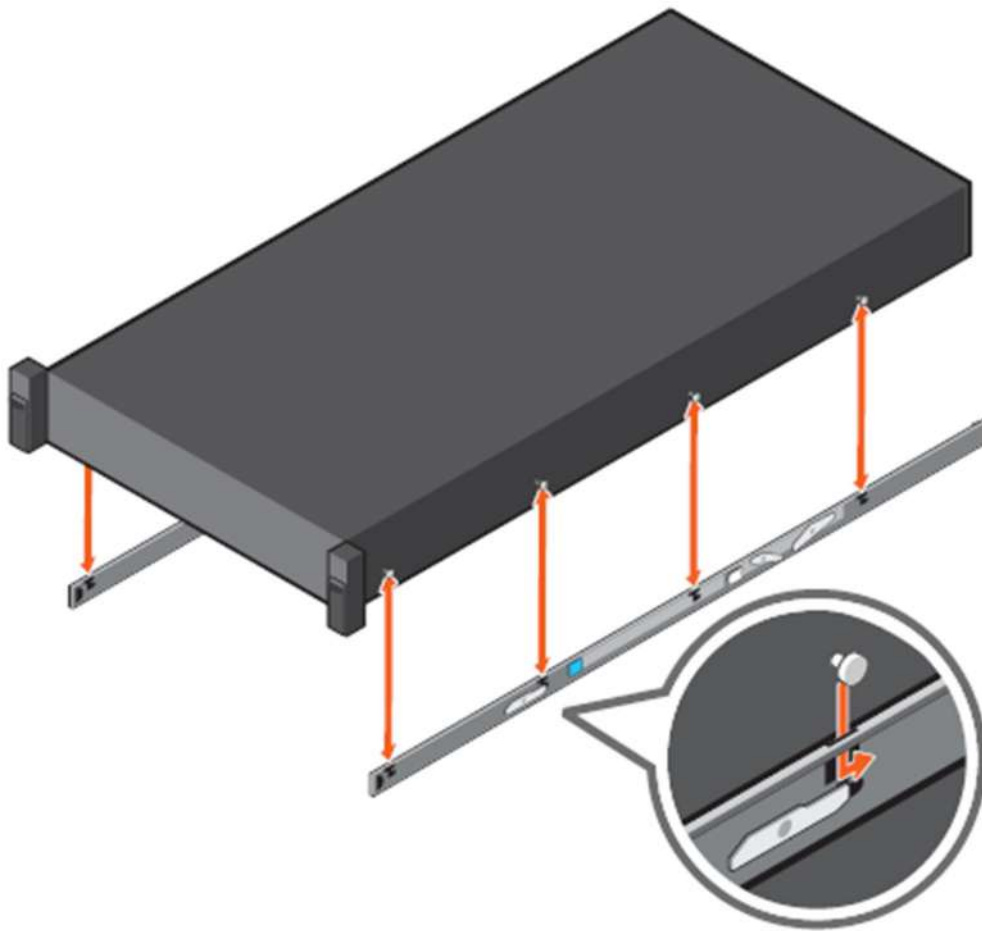

Figure 34. Attach the inner rails to the system

4. With the intermediate rails extended, install the system into the extended rails.

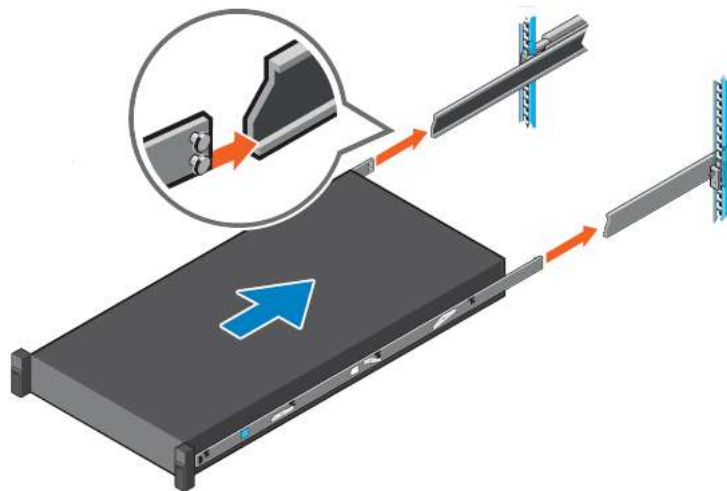

Figure 35. Install system into the extended rails

5. Pull blue slide release lock tabs forward or backward on both rails, and slide the system into the rack.

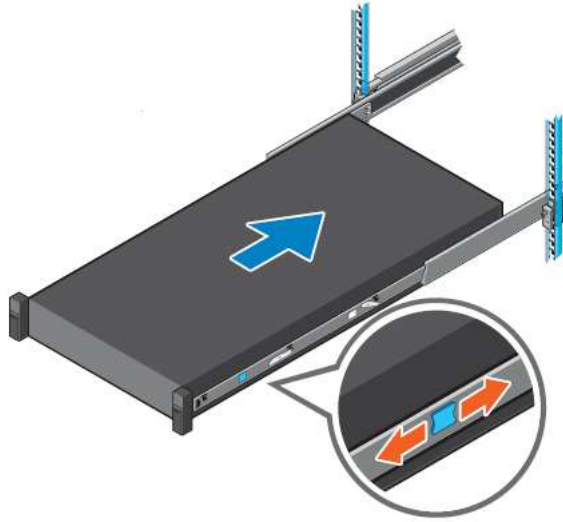

Figure 36. Slide system into the rack

Supported Operating Systems

The PowerEdge system supports the following operating systems:

- Canonical® Ubuntu® Server LTS
- Microsoft® Windows Server® with Hyper-V
- Red Hat® Enterprise Linux
- SUSE® Linux Enterprise server
- VMware® ESXi®

Links to specific OS versions and editions, certification matrices, Hardware Compatibility Lists (HCL) portal, and Hypervisor support are available at [Dell Enterprise Operating Systems](#).

Dell OpenManage Systems Management

Dell delivers management solutions that help IT administrators effectively deploy, update, monitor, and manage IT assets. OpenManage solutions and tools enable you to quickly respond to problems by helping them to manage Dell servers efficiently; in physical, virtual, local, and remote environments; all without the need to install an agent in the operating system.

The OpenManage portfolio includes:

- Innovative embedded management tools - integrated Dell Remote Access Controller (iDRAC)
- Consoles - OpenManage Enterprise
- Extensible with plug-ins - OpenManage Power Manager
- Update tools - Repository Manager

Dell has developed comprehensive systems management solutions that are based on open standards and has integrated with management consoles from partners such as Microsoft and VMware, allowing advanced management of Dell servers. Dell management capabilities extend to offerings from the industry's top systems management vendors and frameworks such as Ansible, Splunk, and ServiceNow. OpenManage tools automate the full span of server life cycle management activities along with powerful RESTful APIs to script or integrate with your choice of frameworks.

For more information about the entire OpenManage portfolio, see:

- The latest [Dell Systems Management Overview Guide](#).

Topics:

- [Integrated Dell Remote Access Controller \(iDRAC\)](#)
- [Systems Management software support matrix](#)

Integrated Dell Remote Access Controller (iDRAC)

iDRAC9 delivers advanced, agent-free, local and remote server administration. Embedded in every PowerEdge server, iDRAC9 provides a secure means to automate a multitude of common management tasks. Because iDRAC is embedded within every PowerEdge server, there is no additional software to install; just plug in power and network cables, and iDRAC is ready to go. Even before installing an operating system (operating system) or hypervisor, IT administrators have a complete set of server management features at their fingertips.

With iDRAC9 in-place across the Dell PowerEdge portfolio, the same IT administration techniques and tools can be applied throughout. This consistent management platform allows easy scaling of PowerEdge servers as an organization's infrastructure grows. Customers can use the iDRAC RESTful API for the latest in scalable administration methods of PowerEdge servers. With this API, iDRAC enables support for the Redfish standard and enhances it with Dell extensions to optimize at-scale management of PowerEdge servers. By having iDRAC at the core, the entire OpenManage portfolio of Systems Management tools allows every customer to tailor an effective, affordable solution for any size environment.

Zero Touch Provisioning (ZTP) is embedded in iDRAC. ZTP - Zero Touch Provisioning is Intelligent Automation Dell's agent-free management puts IT administrators in control. Once a PowerEdge server is connected to power and networking, that system can be monitored and fully managed, whether you're standing in front of the server or remotely over a network. In fact, with no need for software agents, an IT administrator can: · Monitor · Manage · Update · Troubleshoot and remediate Dell servers With features like zero-touch deployment and provisioning, iDRAC Group Manager, and System Lockdown, iDRAC9 is purpose-built to make server administration quick and easy. For those customers whose existing management platform utilizes in-band management, Dell does provide iDRAC Service Module, a lightweight service that can interact with both iDRAC9 and the host operating system to support legacy management platforms.

When ordered with DHCP enabled from the factory, PowerEdge servers can be automatically configured when they are initially powered up and connected to your network. This process uses profile-based configurations that ensure each server is configured per your specifications. This feature requires an iDRAC Enterprise license.

iDRAC9 offers following license tiers:

Table 22. iDRAC9 license tiers

License	Description
iDRAC9 Basic	<ul style="list-style-type: none"> Available only on 100-500 series rack/tower Basic instrumentation with iDRAC web UI For cost conscious customers that see limited value in management
iDRAC9 Express	<ul style="list-style-type: none"> Default on 600+ series rack/tower, modular, and XR series Includes all features of Basic Expanded remote management and server life-cycle features
iDRAC9 Enterprise	<ul style="list-style-type: none"> Available as an upsell on all servers Includes all features of Basic and Express. Includes key features such as virtual console, AD/LDAP support, and more Remote presence features with advanced, Enterprise-class, management capabilities
iDRAC9 Datacenter	<ul style="list-style-type: none"> Available as an upsell on all servers Includes all features of Basic, Express, and Enterprise. Includes key features such as telemetry streaming, Thermal Manage, automated certificate management, and more Extended remote insight into server details, focused on high end server options, granular power, and thermal management

For a full list of iDRAC features by license tier, see [Integrated Dell Remote Access Controller 9 User's Guide](#) at [Dell.com](#).

For more details on iDRAC9 including white papers and videos, see:

- [Support for Integrated Dell Remote Access Controller 9 \(iDRAC9\)](#) on the [Knowledge Base](#) page at [Dell.com](#)

Systems Management software support matrix

Table 23. Systems Management software support matrix

Categories	Features	PE mainstream
Embedded Management and In-band Services	iDRAC9 (Express, Enterprise, and Datacenter licenses)	Supported
	OpenManage Mobile	Supported
	OM Server Administrator (OMSA)	Supported
	iDRAC Service Module (iSM)	Supported
	Driver Pack	Supported
Change Management	Update Tools (Repository Manager, DSU, Catalogs)	Supported
	Server Update Utility	Supported
	Lifecycle Controller Driver Pack	Supported
	Bootable ISO	Supported
Console and Plug-ins	OpenManage Enterprise	Supported
	Power Manager Plug-in	Supported
	Update Manager Plug-in	Supported
	SupportAssist Plug-in	Supported
	CloudIQ	Supported
Integrations and connections	OM Integration with VMware Vcenter/vROps	Supported
	OM Integration with Microsoft System Center (OMIMSC)	Supported
	Integrations with Microsoft System Center and Windows Admin Center (WAC)	Supported

Table 23. Systems Management software support matrix (continued)

Categories	Features	PE mainstream
	ServiceNow	Supported
	Ansible	Supported
	Third-party Connectors (Nagios, Tivoli, Microfocus)	Supported
Security	Secure Enterprise Key Management	Supported
	Secure Component Verification	Supported
Standard operating system	Red Hat Enterprise Linux, SUSE, Windows Server 2021 Ubuntu, CentOS	Supported (Tier-1)

Appendix D: Service and support

Topics:

- [Default support levels](#)
- [Other services and support information](#)

Default support levels

This system offers 3 years Dell ProSupport Next Business Day (NBD), including 24x7 phone support and NBD parts and labor support.

Default deployment levels

This system is defaulted to ProDeploy Dell Server which includes onsite hardware installation and software configuration. Optionally, the customer may choose to any of the factory or field deployment offers listed below.

Other services and support information

Dell Technologies Services include a wide, customizable range of service options to simplify the assessment, design, implementation, management and maintenance of IT environments and to help transition from platform to platform.

Depending on the current business requirements and correct level of service for customers, we provide factory, onsite, remote, modular, and specialized services that fit the customer requirements and budget. We will help with a little or a lot, based on the customers choice, and provide access to our global resources.

Dell deployment services

[Dell ProDeploy Infrastructure Suite](#)

ProDeploy Infrastructure Suite provides a variety of deployment offerings that satisfy a customer's unique needs. It is made up of 5 offers: ProDeploy Configuration Services, ProDeploy Rack Integration Services, Basic Deployment, ProDeploy, and ProDeploy Plus.

ProDeploy Infrastructure Suite for servers

Versatile choices for accelerated deployments

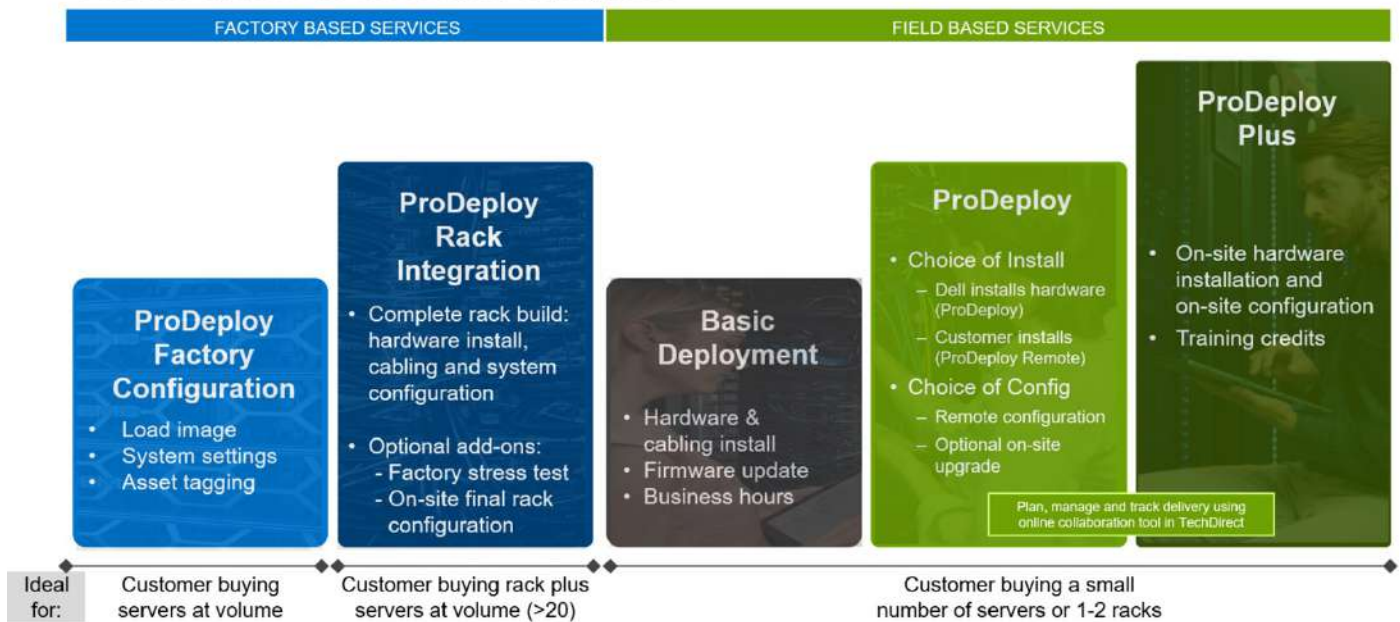

Figure 37. ProDeploy Infrastructure Suite for servers

The new Factory Services consist of two tiers of deployment that happen prior to shipping to the customer's site.

Factory Based Services:

- ProDeploy Factory Configuration - Ideal for customers buying servers in volume and seeking pre-configuration prior to shipping such as: custom image, system settings, and asset tagging so it arrives ready to use out of the box. Furthermore, servers can be packaged and bundled to meet specific shipping and distribution requirements for each customer location to facilitate the rollout process. Upsell one of the field based services (below) if a customer needs assistance with the final server installation.
- ProDeploy Rack Integration - Ideal for customers seeking to build out fully integrated racks prior to shipping. These rack builds include hardware install, cabling, and full system configuration. You can also add-on a factory stress test and optional on-site final rack configuration to complete the rack installation.
 - STANDARD SKUs for Rack Integration is available in US only and requires:
 - 20 or more devices (R and C series servers and all Dell or non-Dell switches). Use Informational SKUs for Dell switches or 3rd party products
 - Shipping to contiguous US
 - USE CUSTOM QUOTE for Rack Integration for:
 - All countries except USA
 - Racks containing less than 20 servers
 - Any rack that includes VxRail or Storage
 - Shipping outside contiguous US
 - Shipping to multiple locations

Field Based Services:

- Basic Deployment consists of the hardware installation, cabling and firmware update during normal standard business hours. Basic Deployment is traditionally sold to Competency Enabled Partners. Competency enabled partners often have Dell do the hardware installation while they complete the software configuration.
- ProDeploy consists of your hardware installation and configuration of the software using offshore resources. ProDeploy is great for customers who are price sensitive or who are remote from their data centers and don't require an onsite presence.
- ProDeploy Plus will give you in-region or onsite resources to complete the engagement for the customer. It also comes with additional features such as Post Deployment Configuration Assistance and Training Credits.

ProDeploy Infrastructure Suite | Factory services

FACTORY BASED SERVICES

		ProDeployFactory Configuration	ProDeploy Rack Integration
Asset configuration	Single point of contact for project management	●	●
	RAID, BIOS and iDRAC configuration	●	●
	Firmware freeze	●	●
	Asset Tagging and Reporting	●	●
	Customer system image	●	●
Factory implementation	Site readiness review and implementation planning	-	●
	Hardware racking and cabling	-	●
	SAM engagement for ProSupport Plus entitled accounts/devices	-	●
	Deployment verification, documentation, and knowledge transfer	●	●
Delivery	White glove logistics	-	●
	Onsite final configuration	-	Onsite add-on
	Install support software and connect with Dell Technologies	-	Onsite add-on
	Basic Deployment	Optional onsite installation	-
Online oversight	Online collaborative environment for planning, managing and tracking delivery	-	●

1 ProDeployRackIntegration Servers are currently only available within the United States.Customer add integration services are still available globally*

DELL Technologies

Figure 38. ProDeploy Infrastructure Suite - Factory services

ProDeploy Infrastructure Suite | Field services

		Basic Deployment	ProDeploy	ProDeploy Plus
Pre-deployment	Single point of contact for project management	●	●	In-region
	Site readiness review	-	●	●
	Implementation planning ¹	-	●	●
	SAM engagement for ProSupport Plus entitled devices	-	-	●
Deployment	Deployment service hours	Business hours	24x7	24x7
	Onsite hardware installation and packaging material removal ² or remote guidance for hardware installation ¹	●	Remote guidance or onsite	Onsite
	Install and configure system software	-	Remote	Onsite
	Install support software and connect with Dell Technologies	-	●	●
	Project documentation with knowledge transfer	-	●	●
Post-deployment	Deployment verification	-	●	●
	Configuration data transfer to Dell Technologies technical support	-	●	●
	30-days of post-deployment configuration assistance	-	-	●
	Training credits for Dell Technologies Education Services	-	-	●
Online oversight	Online collaborative environment in TechDirect for planning, managing and tracking delivery ³	-	●	●

¹ Remote option includes project specific instructions, documentation and live expert guidance for hardware installation. Option available for select hardware. [List is available in the backup portion of this customer presentation](#)

² Packaging removal included with onsite hardware installation

³ Included with ProDeploy or ProDeploy Plus, Not included with Basic Deployment

Figure 39. ProDeploy Infrastructure Suite - Field services

Dell ProDeploy Plus for Infrastructure

From beginning to end, ProDeploy Plus provides the skill and scale that is must successfully perform demanding deployments in today's complex IT environments. Certified Dell experts start with extensive environmental assessments and detailed migration

planning and recommendations. Software installation includes set up of our enterprise connectivity solution (secure connect gateway) and OpenManage system management utilities.

Postdeployment configuration assistance, testing, and product orientation services are also available.

Dell ProDeploy for Infrastructure

ProDeploy provides full-service installation and configuration of both server hardware and system software by certified deployment engineers including set up of leading operating systems and hypervisors as well our enterprise connectivity solution (secure connect gateway) and OpenManage system management utilities. To prepare for the deployment, we conduct a site readiness review and implementation planning exercise. System testing, validation, and full project documentation with knowledge transfer complete the process.

Dell Basic Deployment

Basic Deployment delivers worry-free professional installation by experienced technicians who know Dell servers inside and out.

Additional Deployment Services

You can tailor the ProDeploy Infrastructure Suite offer to meet your customer's unique needs by leveraging "Additional Deployment Time." ADT will cover additional tasks above the normal scope of the standard offers. ADT can be sold for Project Management or Technical Resources and is sold as blocks of four hours remote or eight hours on-site.

Dell ProDeploy for HPC (available in US/Canada only. All other regions use custom)

HPC deployments require specialists that understand that cutting edge is yesterday's news. Dell deploys the world 's fastest systems and understands the nuances that make them perform. ProDeploy for HPC provides:

- Global team of dedicated HPC specialists
- Proven track record, thousands of successful HPC deployments
- Design validation, benchmarking, and product orientation

Learn more at Dell.com/HPC-Services.

ProDeploy Expansion for HPC

*Available as standard SKUs in US & Canada and as custom quote in APJC, EMEA, LATAM

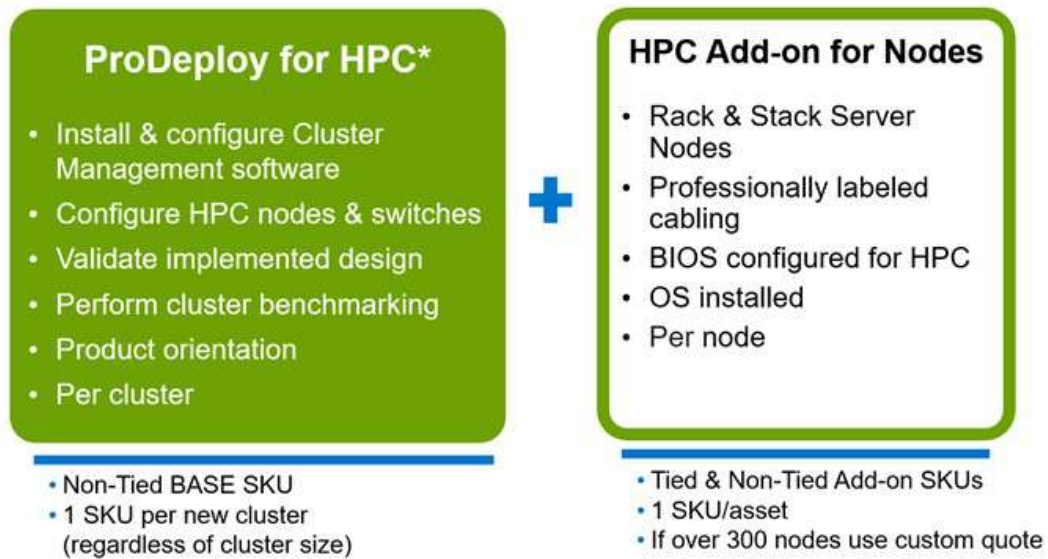

Figure 40. ProDeploy Expansion for HPC

Dell custom deployment Services

Dell custom rack integration and other Dell configuration services help customers save time by providing systems that are racked, cabled, tested, and ready to be integrated into the data center. Dell support preconfigure RAID, BIOS and iDRAC settings, install system images, and even install third-party hardware and software.

For more information, see [Server Configuration Services](#).

Dell Residency Services

Residency Services help customers transition to new capabilities quickly with the assistance of onsite or remote Dell experts whose priorities and time they control.

Residency experts can provide post implementation management and knowledge transfer that is related to a new technology acquisition or day-to-day operational management of the IT infrastructure.

Dell Data Migration Services

Protect business and data of the customer with our single point of contact to manage data migration projects.

A customer project manager works with our experienced team of experts to create a plan using industry-leading tools and proven processes that are based on global best practices to migrate existing files and data, so business systems are up and running quickly and smoothly.

Dell Enterprise Support Services

Dell ProSupport Enterprise Suite

With the ProSupport Enterprise Suite, we help keep IT systems running smoothly, so customers can focus on running their business. We help maintain peak performance and availability of the most essential workloads. ProSupport Enterprise Suite is a suite of support services that enable customers to build the solution that is right for their organization. They choose support models that are based on how they use technology and where they want to allocate resources. From the desktop to the data center, address everyday IT challenges, such as unplanned downtime, mission-critical needs, data and asset protection, support planning, resource allocation, software application management and more. Optimize customer IT resources by choosing the right support model.

Table 24. ProSupport Enterprise Suite

Service	Support model	Description
ProSupport Enterprise Suite	ProSupport Plus for Enterprise	Proactive, predictive, and reactive support for systems that look after your business-critical applications and workloads
	ProSupport for Enterprise	Comprehensive 24 x 7 support
	Basic hardware support	Reactive hardware support during normal business hours

Dell ProSupport Plus for Enterprise

When customers purchase PowerEdge server, we recommend ProSupport Plus, our proactive and preventative support service for business-critical systems. ProSupport Plus provides all the benefits of ProSupport, plus the following:

- An assigned Services Account Manager who knows their business and environment
- Immediate advanced troubleshooting from an engineer
- Personalized, preventive recommendations that are based on analysis of support trends and best practices from across the Dell Technologies infrastructure solutions customer base to reduce support issues and improve performance
- Predictive analysis for issue prevention and optimization that is enabled by secure connect gateway technology
- Proactive monitoring, issue detection, notification, and automated case creation for accelerated issue resolution enabled by secure connect gateway
- On-demand reporting and analytics-based recommendations that are enabled by secure connect gateway and TechDirect

Dell ProSupport for Enterprise

ProSupport service offers highly trained experts around the clock and around the globe to address IT needs. We help minimize disruptions and maximize availability of PowerEdge server workloads with:

- 24x7 support through phone, chat and online
- Predictive, automated tools and innovative technology
- A central point of accountability for all hardware and software issues
- Collaborative third-party support
- Hypervisor, operating system and application support
- Consistent experience regardless of where customers are located or what language they speak

 **NOTE:** Subject to service offer country or region availability.

- Optional onsite parts and labor response options including next business day or four-hour mission critical

ProSupport Enterprise Suite Feature Comparison

	Basic	ProSupport	ProSupport Plus
Remote technical support	9x5	24x7	24x7
Covered products	Hardware	Hardware Software	Hardware Software
Onsite hardware support	Next business day	Next business day or 4hr mission critical	Next business day or 4 hr mission critical
3 rd party collaborative assistance		●	●
Self-service case initiation and management		●	●
Access to software updates		●	●
Proactive storage health monitoring, predictive analytics and anomaly detection with CloudIQ and the CloudIQ mobile app		●	●
Priority access to specialized support experts			●
Predictive detection of hardware failures			●
3 rd party software support			●
An assigned Service Account Manager			●
Proactive, personalized assessments and recommendations			●
Proactive systems maintenance			●

Availability and terms of Dell Technologies Services vary by region and by product. For more information, please view our [service descriptions](#).

© 2022 Dell Technologies. All rights reserved.

Figure 41. ProSupport Enterprise Suite

Dell ProSupport One for Data Center

ProSupport One for Data Center offers flexible site-wide support for large and distributed data centers with more than 1,000 assets. This offering is built on standard ProSupport components that leverage our global scale but are tailored to a customer's needs. While not for everyone, this service option offers a truly unique solution for Dell Technologies largest customers with the most complex environments.

- Team of assigned Services Account Managers with remote, on-site options
- Assigned ProSupport One technical and field engineers who are trained on the customer's environment and configurations
- On-demand reporting and analytics-based recommendations that are enabled by secure connect gateway and TechDirect
- Flexible on-site support and parts options that fit their operational model
- A tailored support plan and training for their operations staff

Dell ProSupport Add-on for HPC

The ProSupport Add-on for HPC provides solution-aware support including:

- Access to senior HPC experts
- Advanced HPC cluster assistance: performance, interoperability, and configuration
- Enhanced HPC solution level end-to-end support
- Remote presupport engagement with HPC Specialists during ProDeploy implementation

Learn more at Dell.com/HPC-Services.

ProSupport Add-on for HPC is an add-on to PS or PSP

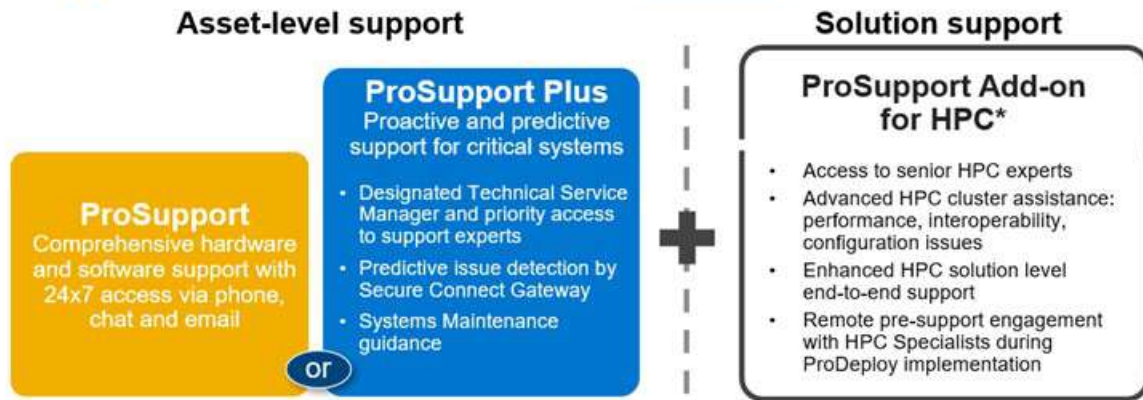

Eligibility

- All server, storage, and networking nodes in cluster must have PS or PSP **AND** PS Add-on for HPC attached
- All HW expansions to clusters must attach PS or PSP **AND** PS Add-on for HPC
- To retrofit an entire existing cluster with PS Add-on for HPC:
 1. HPC Specialists must review and validate the existing cluster
 2. PS or PSP **AND** the PS Add-on for HPC (APOS) must be attached to all server, storage and networking nodes

*Available in standard SKUs in NA and EMEA and as custom quote in APJC & LATAM

DELLTechnologies

Figure 42. ProSupport Add-on for HPC is an add-on to PS or PSP

Support Technologies

Powering the support experience with predictive, data-driven technologies.

NOTE: SupportAssist Enterprise capabilities are now part of the secure connect gateway technology.

Enterprise connectivity

The best time to solve a problem is before it happens. The automated proactive and predictive support features enabled by the secure connect gateway technology helps reduce steps and time to resolution, often detecting issues before they become a crisis. The gateway technology is available in virtual and application editions. It is also implemented as a direct connect version for select Dell hardware and a Services plugin within OpenManage Enterprise for PowerEdge servers. The legacy SupportAssist Enterprise solution has been retired and is now replaced by the secure connect gateway solutions.

Benefits include:

- Value: Our connectivity solutions are available to all customers at no additional charge
- Improve productivity: Replace manual, high-effort routines with automated support
- Accelerate time to resolution: Receive issue alerts, automatic case creation, and proactive contact from Dell experts
- Gain insight and control: Optimize enterprise devices with insights in portals reporting like TechDirect, and get predictive issue detection before the problem starts

NOTE: Connect devices can access these features. Features vary depending on the service level agreement for the connected device. ProSupport Plus customers experience the full set of automated support capabilities.

Table 25. Features enabled by connectivity

	Basic hardware warranty	ProSupport	ProSupport Plus
Automated issue detection and system state information collection	Supported	Supported	Supported
Proactive, automated case creation and notification	Not supported	Supported	Supported

Table 25. Features enabled by connectivity (continued)

—	Basic hardware warranty	ProSupport	ProSupport Plus
Predictive issue detection for failure prevention	Not supported	Not supported	Supported

Get started at DellTechnologies.com/secureconnectgateway.

Dell TechDirect

TechDirect helps boost IT team productivity when supporting Dell systems.

Boost your productivity with online service for Dell products from TechDirect. From deployment to technical support, TechDirect lets you do more with less effort and faster resolution. You can:

- Open and manage support requests or in-warranty systems
- Execute online self-service for parts dispatch
- Collaborate on ProDeploy infrastructure deployment projects online
- Manage proactive and predictive alerts from secure connect gateway technology that help maximize uptime
- Integrate services functionality into your help desk with TechDirect APIs
- Join over 10,000 companies that choose TechDirect

Register at TechDirect.Dell.com.

Dell Technologies Consulting Services

Our expert consultants help customers transform faster, and quickly achieve business outcomes for the high value workloads Dell PowerEdge systems can handle. From strategy to full-scale implementation, Dell Technologies Consulting can help determine how to perform IT, workforce, or application transformation. We use prescriptive approaches and proven methodologies that are combined with portfolio and partner ecosystem of Dell Technologies to help achieve real business outcomes. From multi cloud, applications, DevOps, and infrastructure transformations, to business resiliency, data center modernization, analytics, workforce collaboration, and user experiences-we are here to help.

Dell Managed Services

Some customers prefer Dell to manage the complexity and risk of daily IT operations, Dell Managed Services utilizes proactive, AI enabled delivery operations and modern automation to help customers realize desired business outcomes from their infrastructure investments. With these technologies, our experts run, update and fine-tune customer environments aligned with service levels, while providing environment-wide and down-to-the-device visibility. There are two types of managed service offers. First the outsourcing model or CAPEX model where Dell manages the customer owned assets using our people and tools. The second is the as-a-Service model or OPEX model called APEX. In this service, Dell owns all technology and all the management of it. Many customers will have a blend of the two management types depending on the goals of the organization.

Managed	Outsourcing or CAPEX model	APEX	as-a-Service or OPEX model
<p>We manage your technology using our people and tools.¹</p> <ul style="list-style-type: none"> • Managed detection and response* • Technology Infrastructure • End-user (PC/desktop) • Service desk operations • Cloud Managed (Pub/Private) • Office365 or Microsoft Endpoint 		<p>We own all technology so you can off-load all IT decisions.</p> <ul style="list-style-type: none"> • APEX Cloud Services • APEX Flex on Demand elastic capacity • APEX Data Center Utility pay-per-use model 	

1 – Some minimum device counts may apply. Order via: ClientManagedServices.sales@dell.com

* Managed detection and response covers the security monitoring of laptops, servers, & virtual servers. Min. 50 devices combined. No Networking or Storage-only systems [SAN/NAS]. Available in 32 countries. [Details here](#)

Figure 43. Dell Managed Services

Dell Technologies Education Services

Build the IT skills required to influence the transformational outcomes of the business. Enable talent and empower teams with the right skills to lead and perform transformational strategy that drives competitive advantage. Leverage the training and certification required for real transformation.

Dell Technologies Education Services offers PowerEdge server training and certifications that are designed to help customers achieve more from their hardware investment. The curriculum delivers the information and the practical, firsthand skills that their team must confidently install, configure, manage, and troubleshoot Dell servers.

To learn more or register for a class today, see Education.Dell.com.

Appendix A: Additional specifications

Topics:

- Chassis dimension
- Chassis weight
- NIC port specifications
- Video specifications
- USB ports specifications
- PSU rating
- Environmental Specifications

Chassis dimension

The R660 has the following dimensions:

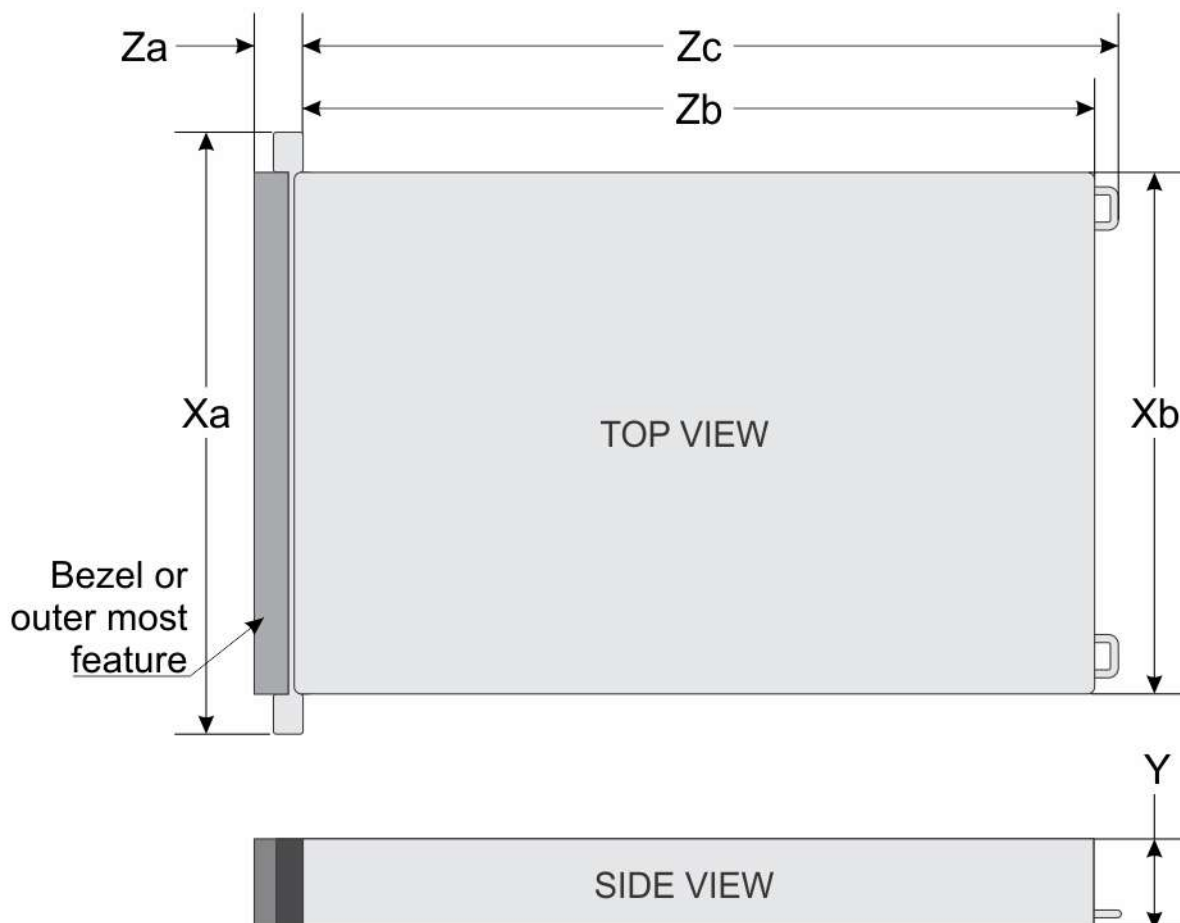

Figure 44. Chassis dimensions

Table 26. PowerEdge R660 system chassis dimension

Drives	Xa	Xb	Y	Za	Zb	Zc
8x2.5" drives / 10x2.5" drives	482.0 mm (18.97 inches)	434.0 mm (17.08 inches)	42.8 mm (1.68 inches)	35.84 mm (1.41 inches) With bezel 22 mm (0.86 inches) Without bezel	751.47 mm (17 inches) Ear to rear wall	787.04 mm (30 inches) Ear to PSU handle
0 drive	482.0 mm (18.97 inches)	434.0 mm (17.08 inches)	42.8 mm (1.68 inches)	35.84 mm (1.41 inches) With bezel 22 mm (0.86 inches) Without bezel	700.7 mm (27.5 inches) Ear to rear wall	736.27 mm (28 inches) Ear to rear wall
14xE3.S drives / 16xE3.S drives	482.0 mm (18.97 inches)	434.0 mm (17.08 inches)	42.8 mm (1.68 inches)	35.84 mm (1.41 inches) With bezel 22 mm (0.86 inches) Without bezel	751.47 mm (17 inches) Ear to rear wall	787.04 mm (30 inches) Ear to PSU handle

NOTE: E3.S drives are supported post RTS.

NOTE: Zb is the nominal rear wall external surface where the system board I/O connectors reside.

Chassis weight

Table 27. PowerEdge R660 system weight

System configuration	Maximum weight (with all drives/SSDs)
A server with fully populated drives	22.51 kg (49.62 lbs)
A server without drives and PSU installed	18.5 kg (40.78 lbs)

NIC port specifications

The system supports up to two 10/100/1000 Mbps Network Interface Controller (NIC) ports embedded on the LAN on Motherboard (LOM) and integrated on the optional OCP cards.

Table 28. NIC port specification for the system

Feature	Specifications
LOM card (optional)	1 GB x 2
OCP card (OCP 3.0) (optional)	1 GbE x 4, 10 GbE x 2, 25 GbE x 2, 25 GbE x 4

NOTE: The system allows either LOM card or an OCP card or both to be installed in the system.

NOTE: On the system board, the supported OCP PCIe width is x8; when x16 PCIe width is installed, it is downgraded to x8.

Video specifications

The platform supports the following video resolution and refresh rates:

Table 29. Video specifications for R660

Resolution	Refresh Rate	Freq.	Pixel Clock	DVO DisplayPort
1024 x 768	60 Hz	48.4 kHz	65.0 MHz	Yes*
1280 x 800	60 Hz	49.7 kHz	83.5 MHz	Yes*
1280 x 1024	60 Hz	64.0 kHz	108.0 MHz	Yes*
1360 x 768	60 Hz	47.71 kHz	85.5 MHz	Yes*
1440 x 900	60 Hz	55.9 kHz	106.5 MHz	Yes*
1600 x 900	60 Hz	55.54 kHz	97.75 MHz	Yes*
1600 x 1200	60 Hz	75.0 kHz	162.0 MHz	Yes*
1680 x 1050	60 Hz	64.7 kHz	119.0 MHz	Yes*
1920 x 1080	60 Hz (RB)	67.158 kHz	173.0 MHz	No
1920 x 1200	60 Hz (RB)	74.556 kHz	193.25 MHz	No

*DVO - DP is for investigation only, dependent on Nuvoton DVO capabilities to support up to 165MHz. Rear Panel Performance is TBD subject to final board design and losses to rear VGA connector.

*(RB) - Reduced Blanking for Digital Displays requiring less blank time. This was introduced for Signal Integrity improvements by reducing Pixel Clock rates for VGA- Analog input devices.

USB ports specifications

Table 30. PowerEdge R660 USB specifications

Front		Rear		Internal (Optional)	
USB port type	No. of ports	USB port type	No. of ports	USB port type	No. of ports
USB 2.0-compliant port	One	USB 2.0-compliant port	One	Internal USB 3.0-compliant port	One
iDRAC Direct port (Micro-AB USB 2.0-compliant port)	One	USB 3.0-compliant port	One		

NOTE: The micro USB 2.0 compliant port can only be used as an iDRAC Direct or a management port.

Front USB 2.0 port only supports output current up to 0.5A and can't support high power consumption devices such as CD-ROM. The bottom port of the rear USB connector can support USB3.0 to supply output current up to 0.9A.



Figure 45. R660 Front USB



Figure 46. R660 Rear USB

PSU rating

Table 31. PSUs Highline and Lowline ratings

Features	700 W Titanium	800 W Platinum	1100 W Titanium	1100 W -48VDC	1400 W Platinum	1800 W Platinum
Peak Power (Highline/-72 VDC)	1190 W	1360 W	1870 W	1870 W	2380 W	3060 W
Highline /-72 VDC	700 W	800 W	1100 W	1100 W	1400 W	1800 W
Peak Power (Lowline/-40 VDC)	N/A	1360 W	1785 W	N/A	1785 W	N/A
Lowline /-40 VDC	N/A	800 W	1050 W	N/A	1050 W	N/A
Highline 240 VDC	700 W	800 W	1100 W	N/A	1400 W	1800 W
DC -48- -60 V	N/A	N/A	N/A	1100 W	N/A	N/A

The PowerEdge R660 supports up to two AC or DC power supplies with 1+1 redundancy, autosensing, and auto-switching capability.

If two PSUs are present during POST, a comparison is made between the wattage capacities of the PSUs. In the event that the PSU wattages don't match, the larger of the two PSU's is enabled. Also, there is a PSU mismatch warning displayed in BIOS, iDRAC, or on the System LCD.

If a second PSU is added at run-time, in order for that particular PSU to be enabled, the wattage capacity of the first PSU must equal the second PSU. Otherwise, the PSU will be flagged as unmatched in iDRAC and the second PSU will not be enabled.

Dell PSUs have achieved Platinum efficiency levels as shown in the table below.

Table 32. PSU Efficiency Levels

Efficiency Targets by Load						
Form factor	Output	Class	10%	20%	50%	100%
Redundant 60mm	700 W AC	Titanium	90.00%	94.00%	96.00%	91.50%
	800 W AC	Platinum	89.00%	93.00%	94.00%	91.50%
	1100 W AC	Titanium	90.00%	94.00%	96.00%	91.50%
	1100 W -48 VDC	N/A	85.00%	90.00%	92.00%	90.00%
	1400 W AC	Platinum	89.00%	93.00%	94.00%	91.50%
	1800 W AC	Titanium	90.00%	94.00%	96.00%	94.00%

Environmental Specifications

See the PowerEdge R660 Technical Specifications on www.dell.com/poweredgemanuals for detailed environmental specifications.

The table below details the environmental specifications for the platform. For additional information about environmental measurements for specific system configurations, see [Product Safety, and Environmental datasheets](#).

An important feature of having a broad menu of different categories is to allow the same platform model to have different operational ranges depending on the MRD defined.

A list of range categories for different configurations shall be identified by thermal team as early in the project as possible. Post release, it may be found in the Dell PowerEdge R660 Installation and Service Manual.

Table 33. Operational climatic range categories

Category A2	Allowable Operation
Temperature Ranges (For Altitude <900 meters or 2953 feet)	10 to 35°C (50 to 95°F) with no direct sunlight on the platform
Humidity Percent Ranges (Non-Condensing at all times)	8%RH with -12°C minimum dew point to 80%RH with 21°C (69.8°F) maximum dew point
Operational Altitude De-Rating	Maximum temperature is reduced by 1°C/300 meters (1.8°F/984 feet) above 900 meters (2,953 feet)

Table 33. Operational climatic range categories

Category A3	Allowable Operation
Temperature Ranges (For Altitude <900 meters or 2953 feet)	5 to 40°C (41 to 104°F) with no direct sunlight on the platform
Humidity Percent Ranges (Non-Condensing at all times)	8%RH with -12°C minimum dew point to 85%RH with 24°C (75.2°F) maximum dew point
Operational Altitude De-Rating	Maximum temperature is reduced by 1°C/175 meters (1.8°F/574 feet) above 900 meters (2,953 feet)

Table 33. Operational climatic range categories

Category A4	Allowable Operation
Temperature Ranges (For Altitude <900 meters or 2953 feet)	5 to 40°C (41 to 104°F) with no direct sunlight on the platform
Humidity Percent Ranges (Non-Condensing at all times)	8%RH with -12°C minimum dew point to 85%RH with 24°C (75.2°F) maximum dew point
Operational Altitude De-Rating	Maximum temperature is reduced by 1°C/175 meters (1.8°F/574 feet) above 900 meters (2,953 feet)

The table below shows the requirements shared across all environmental categories

Table 34. Shared requirements

Allowable Operation	
Maximum Temperature Gradient (applies to both operation and non-operation)	20°C in an hour* (36°F in an hour) and 5°C in 15 minutes (9°F in 15 minutes), 5°C in an hour* (9°F in an hour) for tape hardware
Non-Operational Temperature Limits	-40 to 65°C (-40 to 149°F)
Non-Operational Humidity Limits (Non-Condensing at all times)	5% to 95%RH with 27°C (80.6°F) maximum dew point.
Maximum Non-Operational Altitude	12,000 meters (39,370 feet)
Maximum Operational Altitude	3,048 meters (10,000 feet)

Table 35. Maximum vibration specifications

Maximum vibration	Specifications
Operating	0.26Grms at 5Hz to 350Hz for 10min (all x, y, and z axes)
Storage	1.88Grms at 10Hz to 500Hz for 15min (all six sides tested)

Table 36. Maximum shock specifications

Maximum shock	Specifications
Operating	Six consecutively executed shock pulses in the positive and negative x, y, and z axes of 6G for up to 11ms
Storage	Six consecutively executed shock pulses in the positive and negative x, y, and z axes (one pulse on each side of the system) of 71 G for up to 2 ms.

Thermal air restrictions

ASHRAE A2 environment

- CPU > 300W are not supported in 10 x 2.5 inch storage configuration.
- CPU > 270W are not supported in 10 x 2.5 inch storage with rear drive configuration.
- Maximum 30°C (86°F) for CPU > 270 W in 10 x 2.5 inch storage configuration..
- Maximum 30°C (86°F) for CPU > 250 W with rear drive in 10 x 2.5 inch storage configuration.
- Maximum 30°C (86°F) for CPU > 250 W with 256G RDIMM in 10 x 2.5 inch storage configuration.
- Maximum 30°C (86°F) for CPU > 225 W with 256G RDIMM in 10 x 2.5 rear drive configuration.
- CPU > 350W are not supported in no BP chassis storage configuration.
- Maximum 30°C (86°F) for CPU > 300W in no BP chassis storage configuration.
- CPU > 350W are not supported in 8 x 2.5 inch storage configuration.
- Maximum 30°C (86°F) for CPU > 300 W in 8 x 2.5 inch storage configuration.

ASHRAE A3 environment

- CPU > 185W are not supported in 10 x 2.5 inch storage configuration.
- CPU > 205W are not supported in 8 x 2.5 inch and no BP chassis storage configuration.
- 128 GB or greater capacity RDIMMs are not supported.
- 2.5 inch NVMe storage are not supported in a 8 x 2.5 inch and 10 x 2.5 inch storage configuration.
- Rear drives are not supported.
- Non Dell qualified peripheral cards and/or peripheral cards greater than 25 W are not supported.
- A2 GPU is not supported.
- 85°C (185°F) active optics cable is required.
- Two power supplies are required. System performance may be reduced in the event of a PSU failure.

ASHRAE A4 environment

- CPU > 125W are not supported in 10 x 2.5 inch storage configuration.
- 128 GB or greater capacity RDIMMs are not supported.
- Rear drives are not supported.
- 2.5 inch NVMe storage are not supported.
- BOSS N1 is not supported.
- A2 GPU is not supported.
- Two power supplies are required. System performance may be reduced in the event of a PSU failure.
- Non Dell qualified peripheral cards and/or peripheral cards greater than 25 W are not supported.
- OCP 3.0 card is not supported.
- 85°C (185°F) active optics cable is required.

ASHRAE A3 environment for liquid cooling configuration

- 128 GB or greater capacity RDIMMs are not supported.
- Rear drives are not supported.
- A2 GPU is not supported.

- Two power supplies are required. System performance may be reduced in the event of a PSU failure.
- Non Dell qualified peripheral cards and/or peripheral cards greater than 25 W are not supported.
- 85°C (185°F) active optics cable is required.

ASHRAE A4 environment for liquid cooling configuration

- 128 GB or greater capacity RDIMMs are not supported.
- Rear drives are not supported.
- 2.5 inch NVMe storage are not supported.
- BOSS N1 is not supported.
- A2 GPU is not supported.
- Two power supplies are required. System performance may be reduced in the event of a PSU failure.
- Non Dell qualified peripheral cards and/or peripheral cards greater than 25 W are not supported.
- OCP 3.0 card is not supported.
- 85°C (185°F) active optics cable is required.

Thermal restriction matrix

Table 37. Processor and heat sink matrix

Heat sink	Processor TDP
STD HSK	≤ 185 W
L-type HSK	> 185 W

Table 38. Label reference

Label	Description
STD	Standard
HPR (Gold)	High performance (gold grade)
HSK	Heat sink
LP	Low profile
FH	Full height
DLC	Direct Liquid Cooling

Table 39. Thermal restriction matrix for air cooled configuration

Configuration	No Backplane	8 x 2.5-inch NVMe / SAS/SATA	10x 2.5-inch SAS/SATA	10x 2.5-inch SAS/SATA	10 x 2.5-inch NVMe	10 x 2.5-inch NVMe	Ambient temperature	
	C0		C04-01,C04-02,C04-03,C04-04,C04-05,C04-06,C04-07,C04-08,C04-09	C05-01,C05-03,C05-04,C05-06,C05-13	C05-02,C05-05	C05-07,C05-09		C05-10
Rear storage	No Rear Drives	No Rear Drives	No Rear Drives	2 x 2.5-inch	No Rear Drives	2 x 2.5-inch		
CPU TDP/cTDP	T-Case max center (°C)	Fan						
125 W	79	STD fan	STD fan	STD fan	HPR Gold fan	STD fan	HPR Gold fan	35°C (95°F)

Table 39. Thermal restriction matrix for air cooled configuration (continued)

Configuration		No Backplane	8 x 2.5-inch NVMe / SAS/SATA	10x 2.5-inch SAS/SATA	10x 2.5-inch SAS/SATA	10 x 2.5-inch NVMe	10 x 2.5-inch NVMe	Ambient temperature
		C0	C04-01,C04-02,C04-03,C04-04,C04-05,C04-06,C04-07,C04-08,C04-09	C05-01,C05-03,C05-04,C05-06,C05-13	C05-02,C05-05	C05-07,C05-09	C05-10	
Rear storage		No Rear Drives	No Rear Drives	No Rear Drives	2 x 2.5-inch	No Rear Drives	2 x 2.5-inch	
CPU TDP/cTDP	T-Case max center (°C)	Fan						
150 W	78/79	STD fan	STD fan	STD fan	HPR Gold fan	STD fan	HPR Gold fan	35°C (95°F)
165 W	82/84	STD fan	STD fan	STD fan	HPR Gold fan	STD fan	HPR Gold fan	35°C (95°F)
185 W	80/81/85	STD fan	STD fan	STD fan	HPR Gold fan	STD fan	HPR Gold fan	35°C (95°F)
195 W	64	HPR Gold fan	HPR Gold fan	HPR Gold fan	HPR Gold fan	HPR Gold fan	HPR Gold fan	35°C (95°F)
205 W	76/84/85	HPR Gold fan	HPR Gold fan	HPR Gold fan	HPR Gold fan	HPR Gold fan	HPR Gold fan	35°C (95°F)
225 W	79	HPR Gold fan	HPR Gold fan	HPR Gold fan	HPR Gold fan	HPR Gold fan	HPR Gold fan	35°C (95°F)
250 W	76	HPR Gold fan	HPR Gold fan	HPR Gold fan	HPR Gold fan	HPR Gold fan	HPR Gold fan	35°C (95°F)
270 W	75	HPR Gold fan	HPR Gold fan	HPR Gold fan	HPR Gold fan*	HPR Gold fan	HPR Gold fan*	35°C (95°F)
270 W	71	HPR Gold fan	HPR Gold fan	HPR Gold fan	HPR Gold fan*	HPR Gold fan	HPR Gold fan*	35°C (95°F)
300 W	81	HPR Gold fan	HPR Gold fan	HPR Gold fan*	Required DLC	HPR Gold fan*	Required DLC	35°C (95°F)
300 W	76	HPR Gold fan	HPR Gold fan	HPR Gold fan*	Required DLC	HPR Gold fan*	Required DLC	35°C (95°F)
300 W	77	HPR Gold fan	HPR Gold fan	HPR Gold fan*	Required DLC	HPR Gold fan*	Required DLC	35°C (95°F)
300 W	75	HPR Gold fan	HPR Gold fan	HPR Gold fan*	Required DLC	HPR Gold fan*	Required DLC	35°C (95°F)
300 W	76	HPR Gold fan	HPR Gold fan	HPR Gold fan*	Required DLC	HPR Gold fan*	Required DLC	35°C (95°F)
330 W	77	HPR Gold fan*	HPR Gold fan*	Required DLC	Required DLC	Required DLC	Required DLC	35°C (95°F)
350 W	79	HPR Gold fan*	HPR Gold fan*	Required DLC	Required DLC	Required DLC	Required DLC	35°C (95°F)

Table 39. Thermal restriction matrix for air cooled configuration (continued)

Configuration		No Backplane	8 x 2.5-inch NVMe / SAS/SATA	10x 2.5-inch SAS/SATA	10x 2.5-inch SAS/SATA	10 x 2.5-inch NVMe	10 x 2.5-inch NVMe	Ambient temperature
		C0	C04-01,C04-02,C04-03,C04-04,C04-05,C04-06,C04-07,C04-08,C04-09	C05-01,C05-03,C05-04,C05-06,C05-13	C05-02,C05-05	C05-07,C05-09	C05-10	
Rear storage		No Rear Drives	No Rear Drives	No Rear Drives	2 x 2.5-inch	No Rear Drives	2 x 2.5-inch	
CPU TDP/cTDP	T-Case max center (°C)	Fan						
350 W	78	HPR Gold fan*	HPR Gold fan*	Required DLC	Required DLC	Required DLC	Required DLC	35°C (95°F)

NOTE:

- *Supported ambient temperature is 30°C (86°F) .
- Required DLC requires <30°C (86°F)

Table 40. Thermal restriction for memory

Configuration	No Backplane	8 x 2.5-inch NVMe /SAS/ SATA	10x 2.5-inch SAS/SATA	10x 2.5-inch SAS/SATA	10 x 2.5-inch NVMe	10 x 2.5-inch NVMe
	C0	C04-01,C04-02,C04-03,C04-04,C04-05,C04-06,C04-07,C04-08,C04-09	C05-01,C05-03,C05-04,C05-06,C05-13	C05-02,C05-05	C05-07,C05-09	C05-10
Rear storage	No Rear Drives	No Rear Drives	No Rear Drives	2 x 2.5-inch	No Rear Drives	2 x 2.5-inch
256 GB RDIMM	35°C (95°F)	35°C (95°F)	30°C (86°F) NOTE: 30°C (86°F) for CPU>250W (CPU<=250W could support 35°C (95°F))	30°C (86°F) NOTE: 30°C (86°F) for CPU>225 W (CPU<=225 W could support 35°C (95°F))	30°C (86°F) NOTE: 30°C (86°F) for CPU>250W (CPU<=250 W could support 35°C (95°F))	30°C (86°F) NOTE: 30°C (86°F) for CPU>225W (CPU<=225 W could support 35°C (95°F))

NOTE:

- Install all fan modules for single CPU configuration.
- NOTE:** Not required for C04-08 configuration.
- All air-cooling configurations require a CPU shroud.
- Install PCH shroud for no riser configuration.
- Install Rear drive shroud for air-cooling with 2x 2.5-inch rear drive configuration.
- Install A2 blank on R1p riser for FH riser configuration with A2 GPU.
- Install DIMM blanks in all empty DIMM slots for STD CPU heat sink or CPU TDP >=250W.

Appendix B. Standards compliance

The system conforms to the following industry standards.

Table 41. Industry standard documents

Standard	URL for information and specifications
ACPI Advance Configuration and Power Interface Specification, v2.0c	https://uefi.org/specsandtesttools
Ethernet IEEE 802.3-2005	https://standards.ieee.org/
HDG Hardware Design Guide Version 3.0 for Microsoft Windows Server	microsoft.com/whdc/system/platform/pcdesign/desguide/serverdg.msp
IPMI Intelligent Platform Management Interface, v2.0	intel.com/design/servers/ipmi
DDR5 Memory DDR5 SDRAM Specification	jedec.org/standards-documents/docs/jesd79-4.pdf
PCI Express PCI Express Base Specification Rev. 2.0 and 3.0	pcisig.com/specifications/pciexpress
PMBus Power System Management Protocol Specification, v1.2	http://pmbus.org/Assets/PDFS/Public/PMBus_Specification_Part_1_Rev_1-1_20070205.pdf
SAS Serial Attached SCSI, v1.1	http://www.t10.org/
SATA Serial ATA Rev. 2.6; SATA II, SATA 1.0a Extensions, Rev. 1.2	sata-io.org
SMBIOS System Management BIOS Reference Specification, v2.7	dmtf.org/standards/smbios
TPM Trusted Platform Module Specification, v1.2 and v2.0	trustedcomputinggroup.org
UEFI Unified Extensible Firmware Interface Specification, v2.1	uefi.org/specifications
USB Universal Serial Bus Specification, Rev. 2.7	usb.org/developers/docs

Appendix C Additional resources

Table 42. Additional resources

Resource	Description of contents	Location
Installation and Service Manual	<p>This manual, available in PDF format, provides the following information:</p> <ul style="list-style-type: none"> • Chassis features • System Setup program • System indicator codes • System BIOS • Remove and replace procedures • Diagnostics • Jumpers and connectors 	Dell.com/Support/Manuals
Getting Started Guide	<p>This guide ships with the system, and is also available in PDF format. This guide provides the following information:</p> <ul style="list-style-type: none"> • Initial setup steps 	Dell.com/Support/Manuals
Rack Installation Guide	<p>This document ships with the rack kits, and provides instructions for installing a server in a rack.</p>	Dell.com/Support/Manuals
System Information Label	<p>The system information label documents the system board layout and system jumper settings. Text is minimized due to space limitations and translation considerations. The label size is standardized across platforms.</p>	Inside the system chassis cover
Quick Resource Locator (QRL)	<p>This code on the chassis can be scanned by a phone application to access additional information and resources for the server, including videos, reference materials, service tag information, and Dell contact information.</p>	Inside the system chassis cover
Enterprise Infrastructure Planning Tool (EIPT)	<p>The Dell online EIPT enables easier and more meaningful estimates to help you determine the most efficient configuration possible. Use EIPT to calculate the power consumption of your hardware, power infrastructure, and storage.</p>	Dell.com/calc